

# ***MLT6SC***

## ***Light Tower Parts Manual***

*S/N 3002908801 and above*

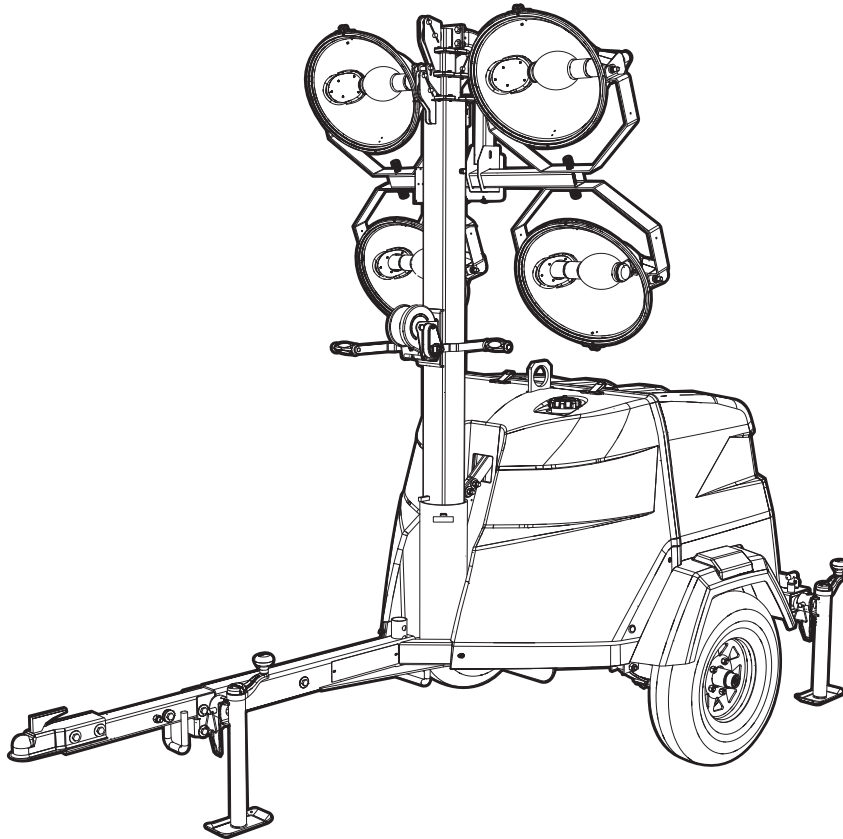

02449

MODEL NUMBER: \_\_\_\_\_

SERIAL NUMBER: \_\_\_\_\_

DATE PURCHASED: \_\_\_\_\_

***SAVE THIS MANUAL FOR FUTURE REFERENCE***

 **WARNING**

Breathing diesel engine exhaust exposes you to chemicals known to the State of California to cause cancer and birth defects or other reproductive harm.

- Always start and operate the engine in a well-ventilated area.
- If in an enclosed area, vent the exhaust to the outside.
- Do not modify or tamper with the exhaust system.
- Do not idle the engine except as necessary.

For more information go to

[www.P65Warnings.ca.gov/diesel](http://www.P65Warnings.ca.gov/diesel). (000394)

# Introduction

This parts manual was prepared based on the information available at the time of publication and is subject to change without notice. Generac Mobile Products reserves the right to change parts at any time. To check whether a revised parts manual is available, contact Generac Mobile Products.

DO NOT MODIFY or use this equipment for any application other than which it was designed for. To keep your equipment fully operational, it is suggested you maintain a stock of commonly used maintenance or service parts. A recommended spare parts list can be found in the back of this manual. To order service parts, please go to [www.generacmobileproducts.com](http://www.generacmobileproducts.com) or call Generac Mobile Products.



## **WARNING**

Consult Manual. Read and understand manual completely before using product. Failure to completely understand manual and product could result in death or serious injury. (000100a)

---

## **WARNING**

Environmental Hazard. Always recycle batteries at an official recycling center in accordance with all local laws and regulations. Failure to do so could result in environmental damage, death or serious injury. (000228)

---

## **GENERAC MOBILE PRODUCTS LLC**

**215 Power Drive • Berlin, WI 54923 U.S.A.**

**Phone: 920-361-4442**

**FAX: 920-361-4416**

**Toll Free: 1-800-926-9768**

**[www.generacmobileproducts.com](http://www.generacmobileproducts.com)**

**For technical or parts QUESTIONS, contact Generac Mobile Products Technical Service at 1-800-926-9768.**

Engine Make: \_\_\_\_\_

Engine Serial Number: \_\_\_\_\_

Engine Model Number: \_\_\_\_\_

This Page Intentionally Left Blank

# Table of Contents

Introduction .....	iii
Parts Manual Instructions .....	1
Unit Decals - Front, Rear and Top.....	2
Unit Decals - Left and Right Sides.....	4
Unit Decals - Inside Unit.....	6
Mast, Junction Box and Lights to Unit .....	8
Light Assembly .....	10
Mast Junction Box Assembly.....	12
Mast Assembly .....	14
Mast Assembly - Bottom Post - Manual Winch .....	16
Mast Assembly - Bottom Post - Electric Winch .....	18
Enclosure Assembly (1 of 2).....	20
Enclosure Assembly (2 of 2).....	22
Control Box Assembly .....	24
Control Box Assembly - Powerzone Option (1 of 2) .....	26
Control Box Assembly - Powerzone Option (2 of 2).....	28
Cooling System Assembly .....	30
Engine Assembly (1 of 2) .....	32
Engine Assembly (2 of 2) .....	34
Generator Assembly .....	36
Components to Trailer Assembly .....	38
Trailer Assembly.....	40
Recommended Spare Parts - Engine .....	42
Recommended Spare Parts - Electrical .....	44
Recommended Spare Parts - Misc.....	46

This Page Intentionally Left Blank

# Parts Manual Instructions

Product illustrations are only representations. Products supplied may vary from the illustrations in this parts manual. Parts not shown in the illustration are indicated by a double dash (--) in the item column.

Please be prepared to provide the following information when ordering replacement parts: model number, serial number (on unit serial tag), part number, purchase order number (if applicable), shipping address, shipping method.

Refer to the illustration below to locate the unit ID tag and Vehicle Identification Number (VIN) tag on the unit. Important information, such as the unit serial number, model number, VIN and tire loading information are found on these tags. Record the information from these tags so it is available if the tags are lost or damaged. When ordering parts or requesting assistance, you may be asked to provide this information.

VIN Tag

MANUFACTURED BY/FABRIQUE PAR: Generac Mobile Products LLC		DATE: 05/00/00	<b>WEIGHT AND LOADING INFORMATION</b> <b>RENSEIGNEMENTS SUR LES</b> <b>PONDS ET LE CHARGEMENT</b> The weight of cargo should never exceed (500KG) (1100LBS) or 60% of the rated capacity. Do not exceed the weight of the cargo.
OVERSEAS: 00000 (00000)	COLD INF. PRESS./ FROID DE		
DATE: 0000/0000	TRAILER / ANTE		SEE GENERAC WEBSITE FOR ADDITIONAL INFORMATION
VIN: 000000000000000000		MODEL: XXX000	VEHICLE SERIAL NUMBER: 000000000000000000
		TYPE: TRAILER	

Unit ID Tag  
(Located on top of control box)

Manufactured by Generac Mobile Products LLC		
(000) 361-4442 (000) 335-0768		
Country of Origin	Model	Serial Number
Manufacturing Code	Weight (Kilograms)	Rated Capacity
1 pin, 1.00P	2 pin, 2.00P	3 pin, 3.00P
RVW		
RVK		
V		
A		

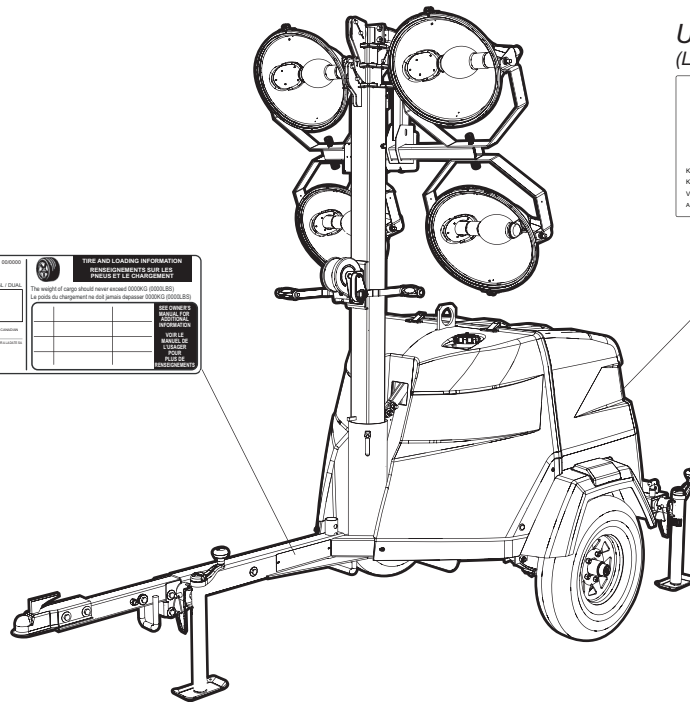

02430





## UNIT DECALS - FRONT, REAR AND TOP

Item	Part No.	Qty	Description	Notes
1	17979	1	Decal, safety MLT6	
2	17980	1	Decal, operation MLT6/ (manual)	
3	76916	1	Decal, operation PZ	Powerzone only
4	10000030392	4	Decal, 1100W bulb system	one each lamp
--	10000031782	2	Cable tie, with decal 10000030392	one on main harness one on light harness

# UNIT DECALS - LEFT AND RIGHT SIDES

1

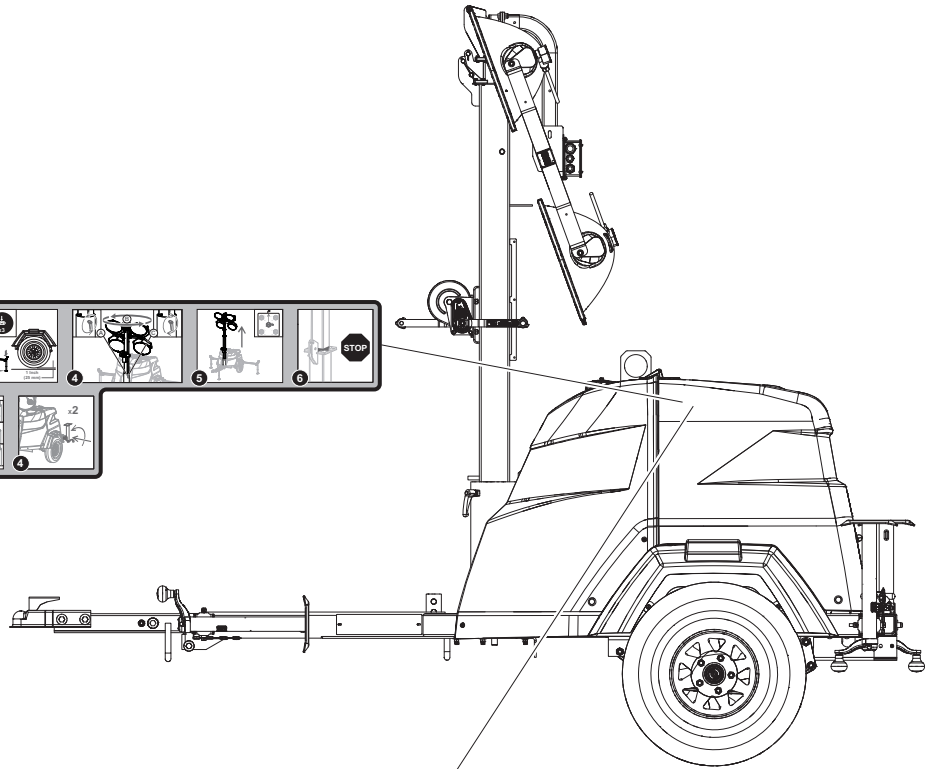
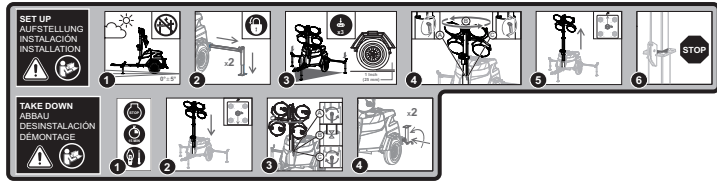

2

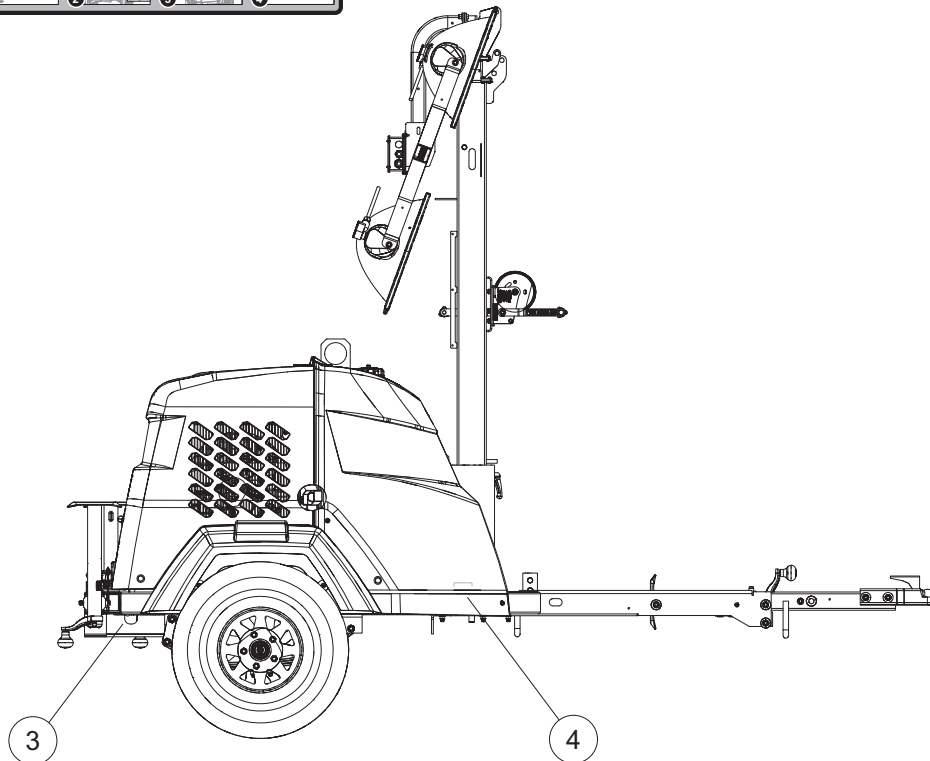
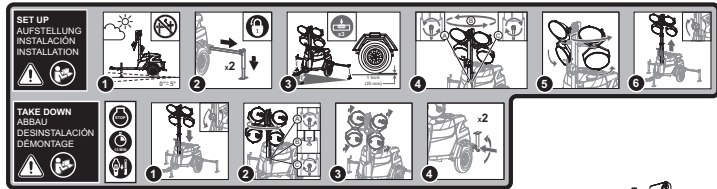

02432

## UNIT DECALS - LEFT AND RIGHT SIDES

---

Item	Part No.	Qty	Description	Notes
1	70096	1	Decal, operation MLT6/8S (electric)	
2	17980	1	Decal, operation MLT6/8S (manual)	
3	72149	1	Reflector, red (4.25 inch x .75 inch)	Set of two
4	72150	1	Reflector, yellow (4.25 inch x .75 inch)	Set of two

# UNIT DECALS - INSIDE UNIT

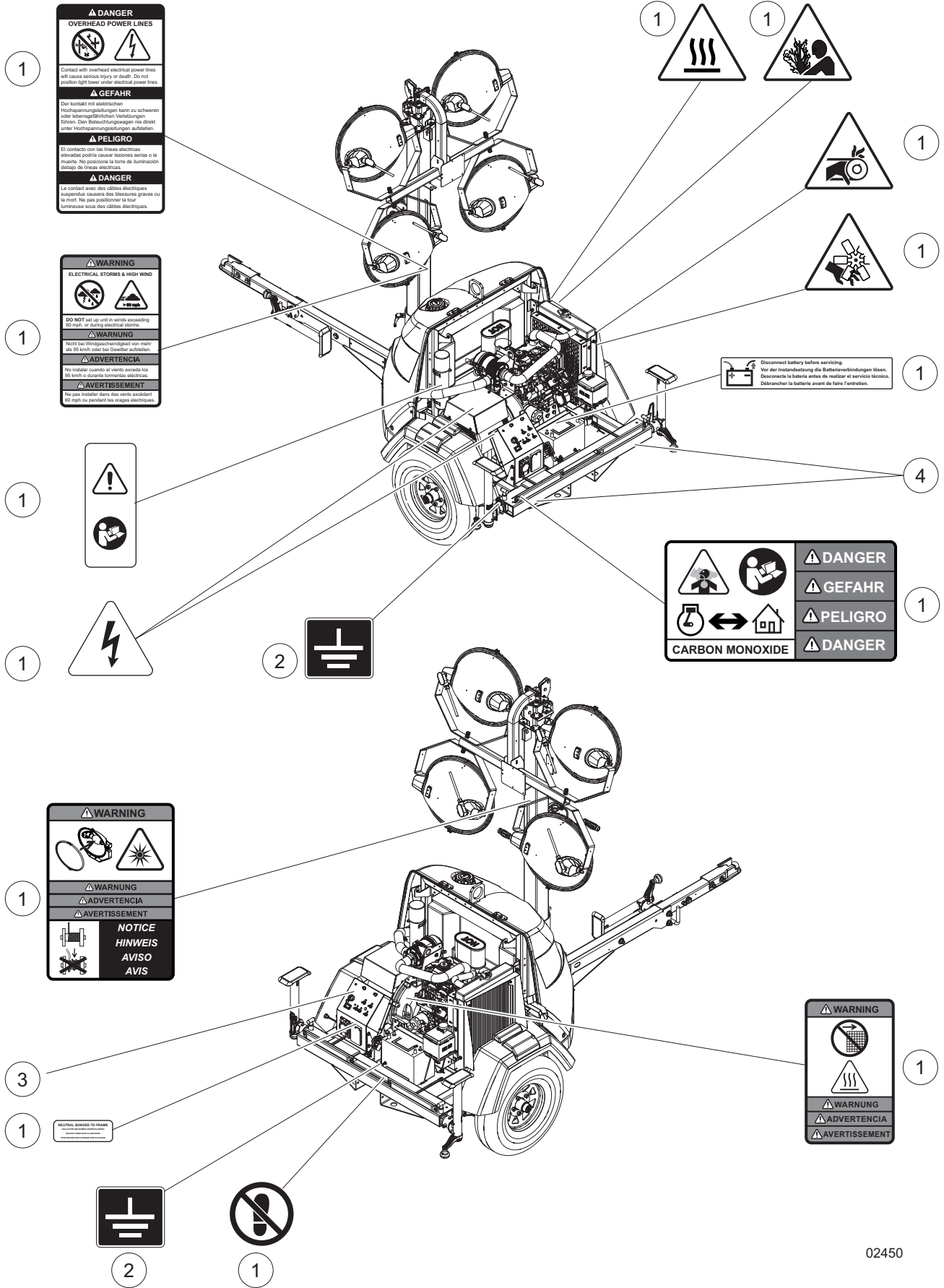

02450

## UNIT DECALS - INSIDE UNIT

---

Item	Part No.	Qty	Description	Notes
1	17979	1	Decal, safety MLT6/8S	
2	12142	1	Decal, ground	
3	17986	1	Decal, control panel MLT 6SK-M	
--	70196	1	Decal, control panel - Powerzone	Powerzone only
4	72132	1	Reflector, rear 2.0 x 2.0 - red	Set of two

# MAST, JUNCTION BOX AND LIGHTS TO UNIT

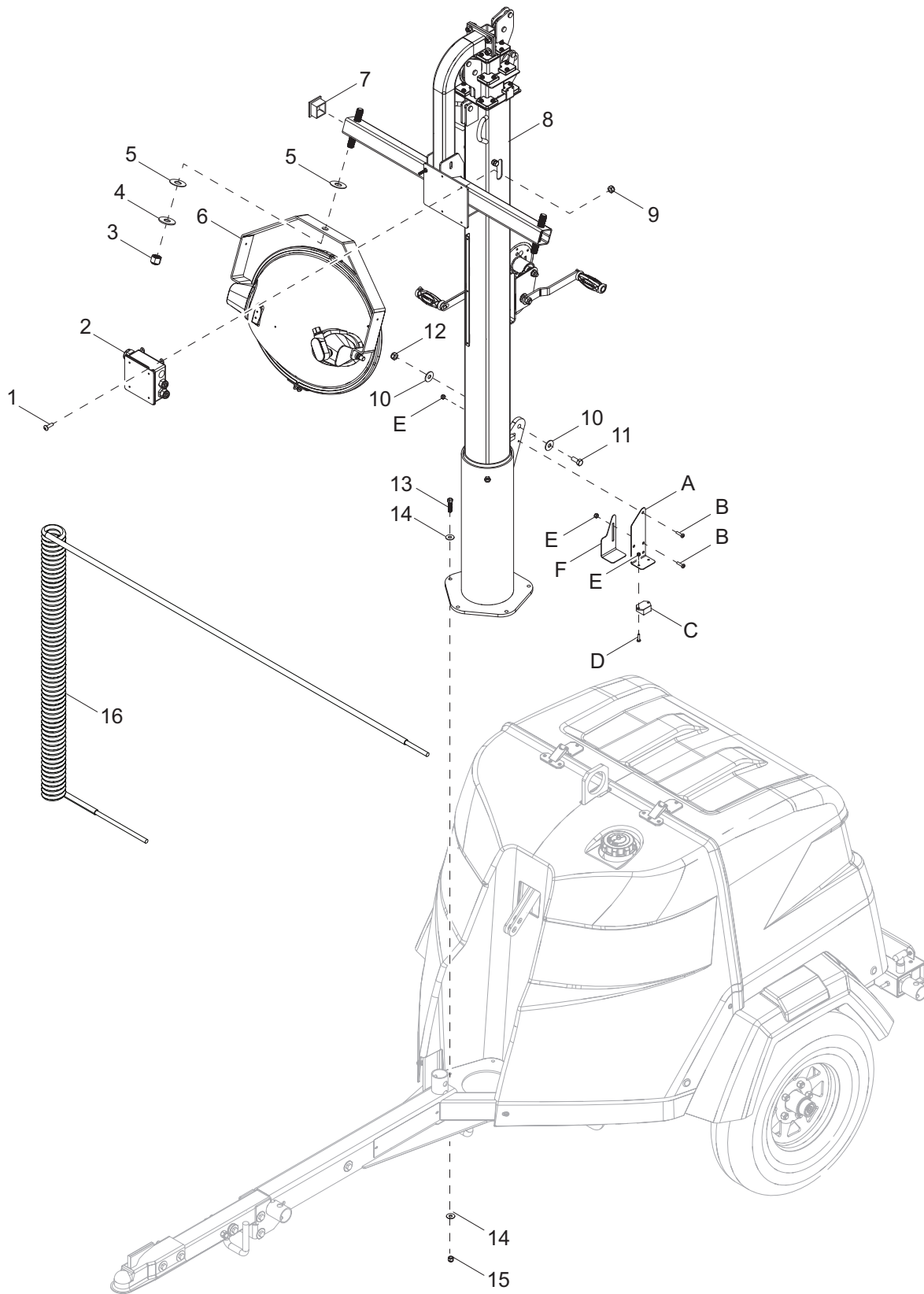

02434

## MAST, JUNCTION BOX AND LIGHTS TO UNIT

Item	Part No.	Qty	Description	Notes
1	60062	4	Screw, 10-32 x .750 pan Phillips, G2	
2	31250SRV	1	Assembly, mast box	
3	60584	4	Nut, .750-10 nylock, G5	
4	60247	4	Washer, .750 flat 2.020/.130	
5	63357	8	Washer, .750 flat 2.0/.062 - plastic	
6	10000022353	4	Assembly, oval light fixture 1100W MH	
7	10000023259	2	Plug, 2.0 square x 14 ga. wall tube, plastic - black	
8	39648	1	Assembly, mast - manual winch, NAP	
9	60415	4	Nut, 10-32 nylock, SS	
10	60309	4	Washer, .500 flat 1.060/.090	
11	60484	2	Screw, .500-13 x 2.0 standard hex, G5	
12	62221	2	Nut, .500-13 nylock, G5	
13	60139	5	Screw, .375-16 x 1.50 hex, G5	
14	60386	10	Washer, .375 flat .993/.064	
15	60358	5	Nut, .375-16 nylock, G5	
16	39650	1	Coil cord with connector	

### *Night Watchman: If equipped*

A	70208B	1	Bracket, night watchman	
B	60488	4	Screw, 8-32 x .750 pan Phillips, G2	
C	68763	1	Assembly, night watchman	
D	62054	2	Screw, 8-32 x .500 pan Phillips 18-8, SS	
E	60270	8	Nut, 8-32 nylock	
F	56610B	1	Cover, dusk to dawn sensor	

# LIGHT ASSEMBLY

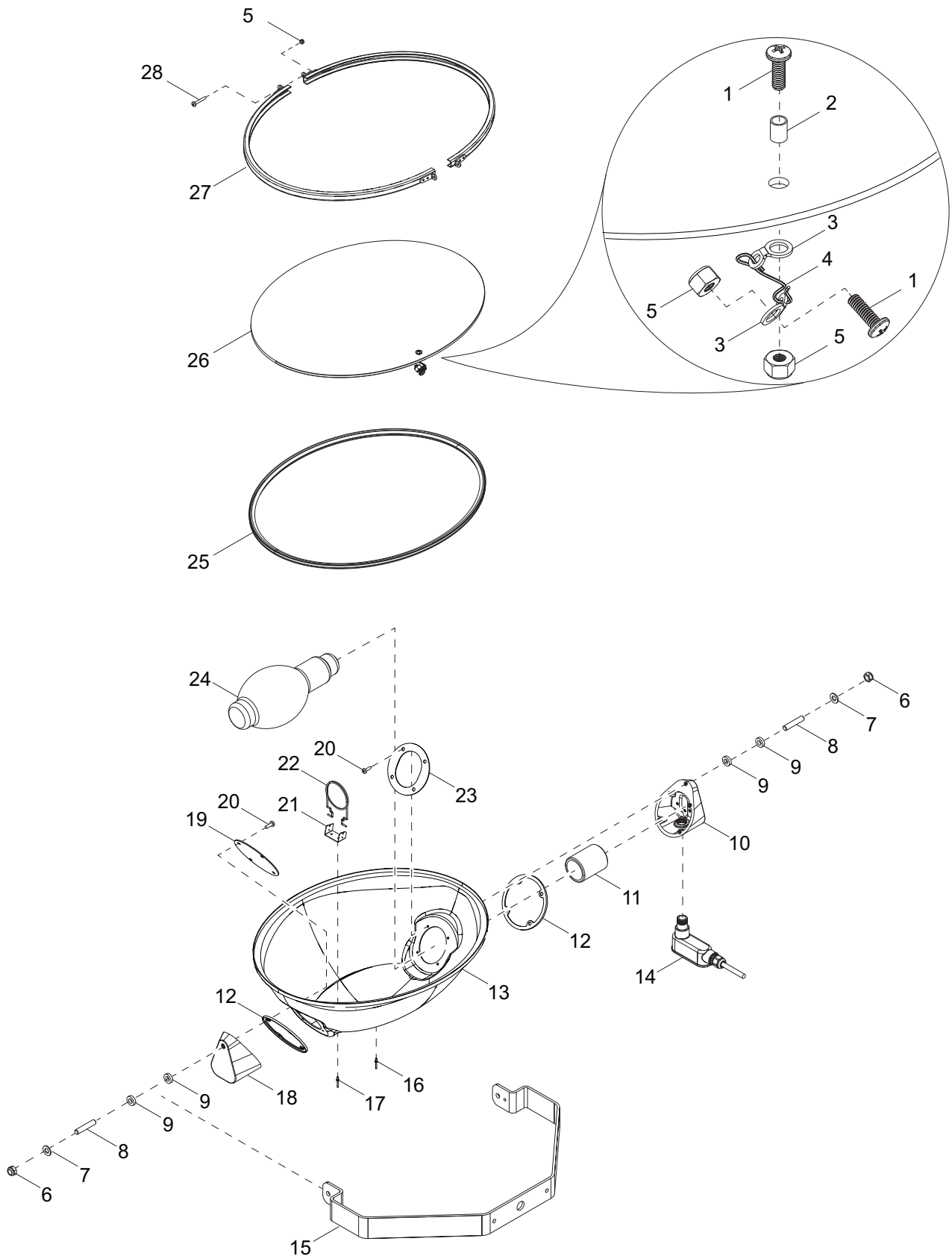

02583



## LIGHT ASSEMBLY - OVAL

Item	Part No.	Qty	Description	Notes
1	10000022372	2	Screw, 8-32 x .500 pan Phillips - SS	
2	10000022307	1	Spacer, .177 ID x .216 OD x .275 - nylon	
3	10000022348	2	Bracket, cable lock	
4	10000022306	1	Cable, lens lock	
5	10000022289	4	Nut, 8-32 hex nylock - SS	
6	10000022349	2	Nut, .375-24 hex nylock - SS	
7	10000022373	2	Washer, .375 flat .413/.787 - SS	
8	10000022401	2	Stud, .375-24 x 2.00	
9	10000022374	4	Washer, .375 nylon .775/.197	
10	10000022356	1	Support, with cord	
11	10000022288	1	Socket, HID light	
12	10000022355	2	Gasket, silicone	
13	10000022370	1	Housing	
14	10000022392	1	Connector, weather tight	
15	10000022410	1	Bracket, trunnion HID light	
16	10000022383	2	Rivet, .134 diameter x .09 to .125 grip - SS	
17	10000022420	2	Rivet, .094 diameter x .09 to .240 grip - SS	
18	10000022354	1	Support, without cord	
19	10000022329	1	Bracket, non socket end	
20	10000022380	8	Screw, 10-24 x .375 hex flanged slotted - SS	
21	10000022390	1	Bracket, light holder	
22	10000022358	1	Support, bulb	
23	10000022357	1	Bracket, socket end	
24	10000022381	1	Bulb, metal halide 1100W	
25	10000022305	1	Gasket, lens	
26	10000022371	1	Lens, glass	
27	10000022400	2	Bracket, lens HSG secure	
28	10000022359	2	Screw, 8-32 x 1.500 pan Phillips - SS	
--	10000022353	4	Assembly, oval light fixture 1100W MH	

# MAST JUNCTION BOX ASSEMBLY

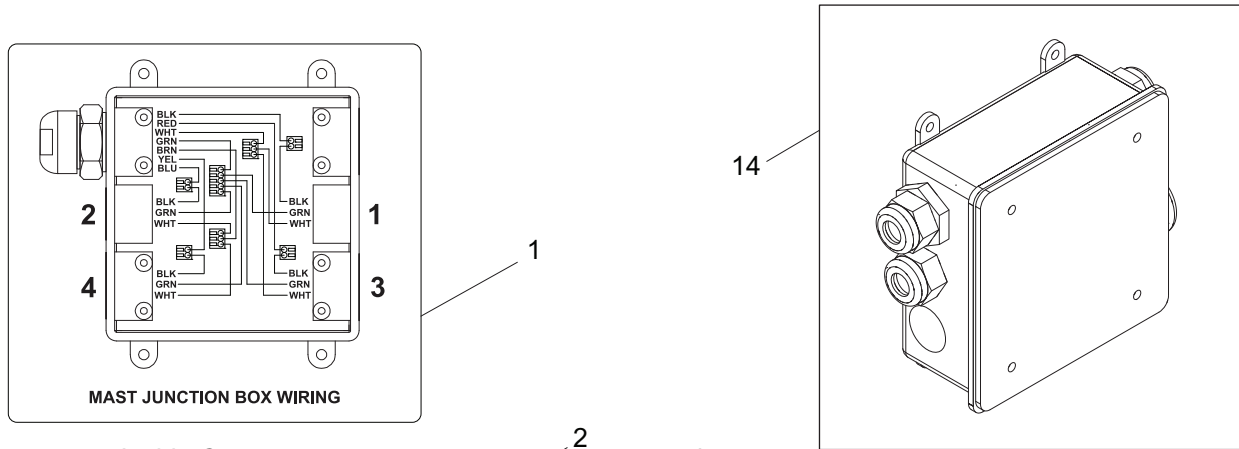

Inside Cover

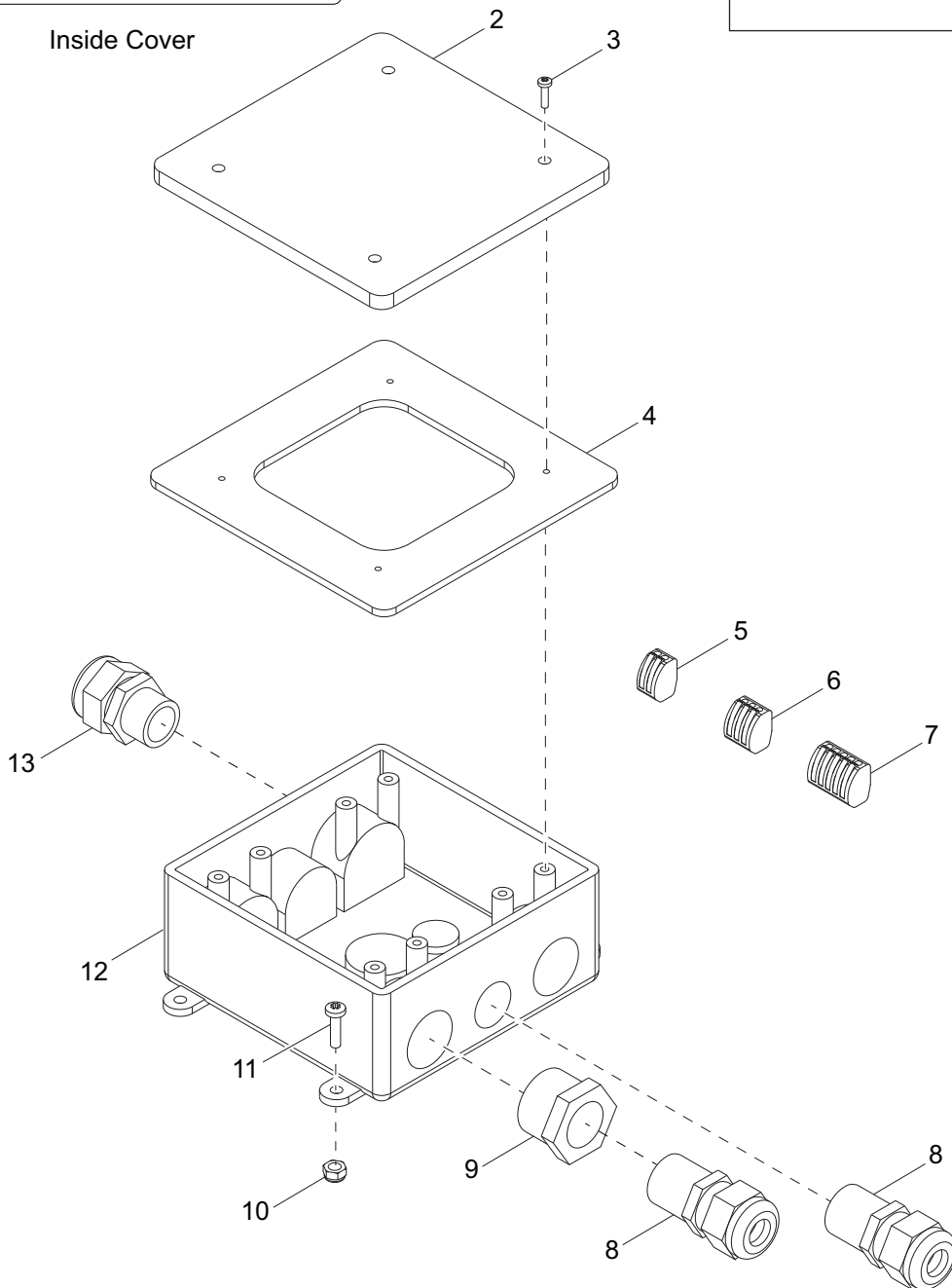

02132

## MAST JUNCTION BOX ASSEMBLY

Item	Part No.	Qty	Description	Notes
1	37215	1	Decal, mast junction box wiring	
2	12109	1	Cover, box, 2-gang plastic	
3	60424	4	Screw, 6-32x.750 pan Phillips, G2	
4	13749SRV	1	Gasket, junction box - HFI 281000	
5	66100	4	Connector, 2 position.	
6	66101	2	Connector, 3 position.	
7	66102	1	Connector, 5 position.	
8	60755	2	Fitting, strt .750MNPT x .500FNPT, nylon	
9	15864	4	Strain relief, .500NPT watertight	
10	60415	4	Nut, 10-32 nylock, SS	
11	60062	4	Screw, 10-32x.750 pan Phillips, G2	
12	12094	1	Box, junction	
13	14656	1	Strain relief, .750NPT watertight	
14	31250SRV	1	Assembly, junction box	

# MAST ASSEMBLY

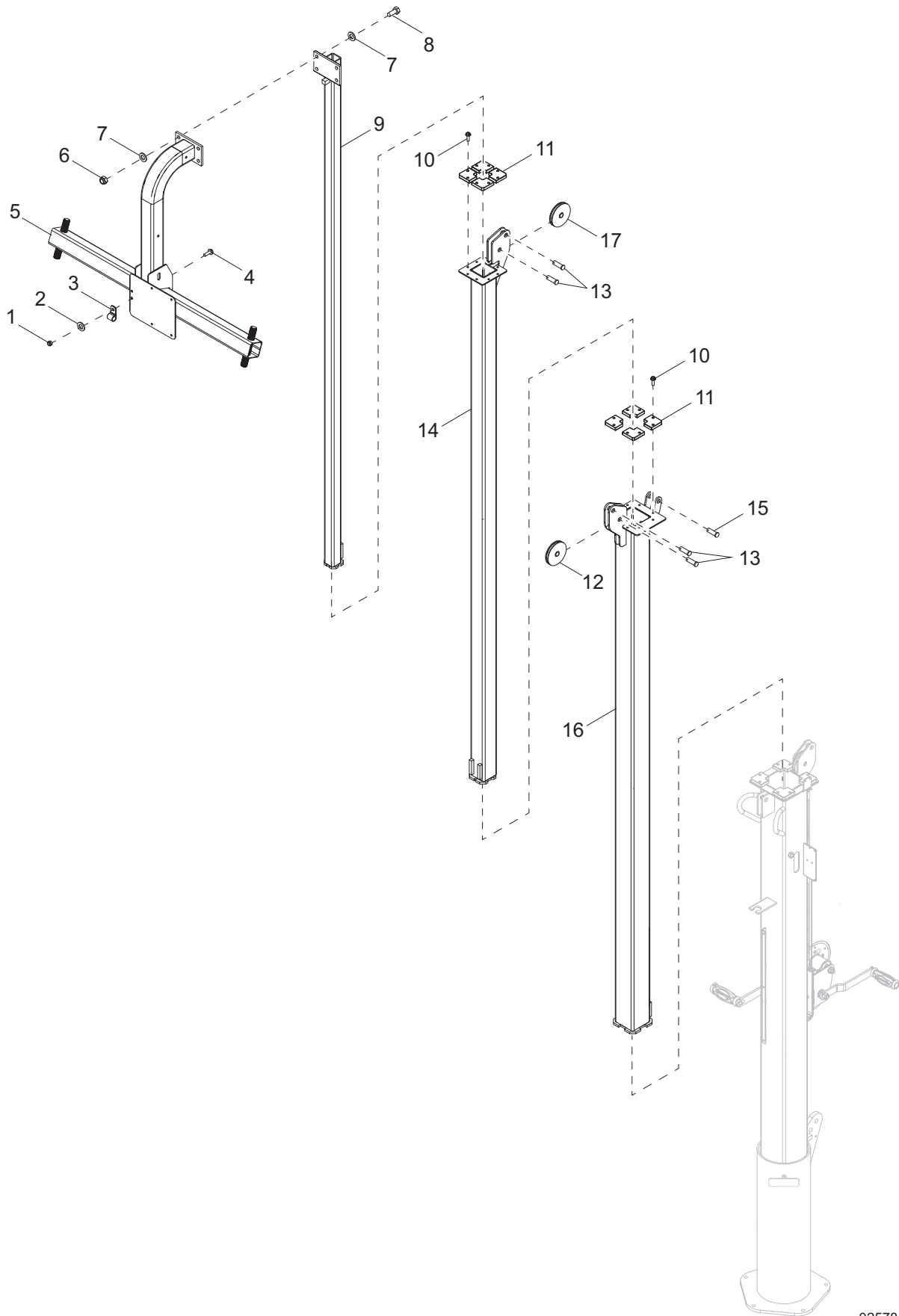

02578

## MAST ASSEMBLY

Item	Part No.	Qty	Description	Notes
1	60144	1	Nut, .250-20 nylock, G5	
2	60243	1	Washer, .250 flat .735/.060	
3	16143	1	Clamp, tubing .500	
4	60107	1	Screw, .250-20 x .750 serrated flange hex, G5	
5	43201B	1	Weldment, mast, crossbar	
6	60358	4	Nut, .375-16 nylock, G5	
7	60386	8	Washer, .375 flat .993/.064	
8	60352	4	Screw, .375-16 x 1.250 hex, G5	
9	31264B	1	Weldment, mast - 1.50	
10	63358	16	Screw, .250-20 x .625 hex wash hd	
11	31225	8	Guide	
12	33736	1	Assembly, pulley - vertical mast	
13	63325	4	Pin, clevis .500 diameter x 1.063 UL	
14	31261B	1	Weldment, mast - 2.25	
15	35655	1	Pin, clevis .500 diameter x 1.750 ZP	
16	37465B	1	Weldment, mast - 3.0	
17	14262	1	Sheave, 3.00	
--	31247	1	Cable, .188 x 144 w/ ball swedge	winch cable
--	31248	2	Cable, .188 x 79.75 w/ball swedge	middle cable
--	31277	1	Cable, .188 x 78.0 w/ball swedge	top cable

# MAST ASSEMBLY - BOTTOM POST - MANUAL WINCH

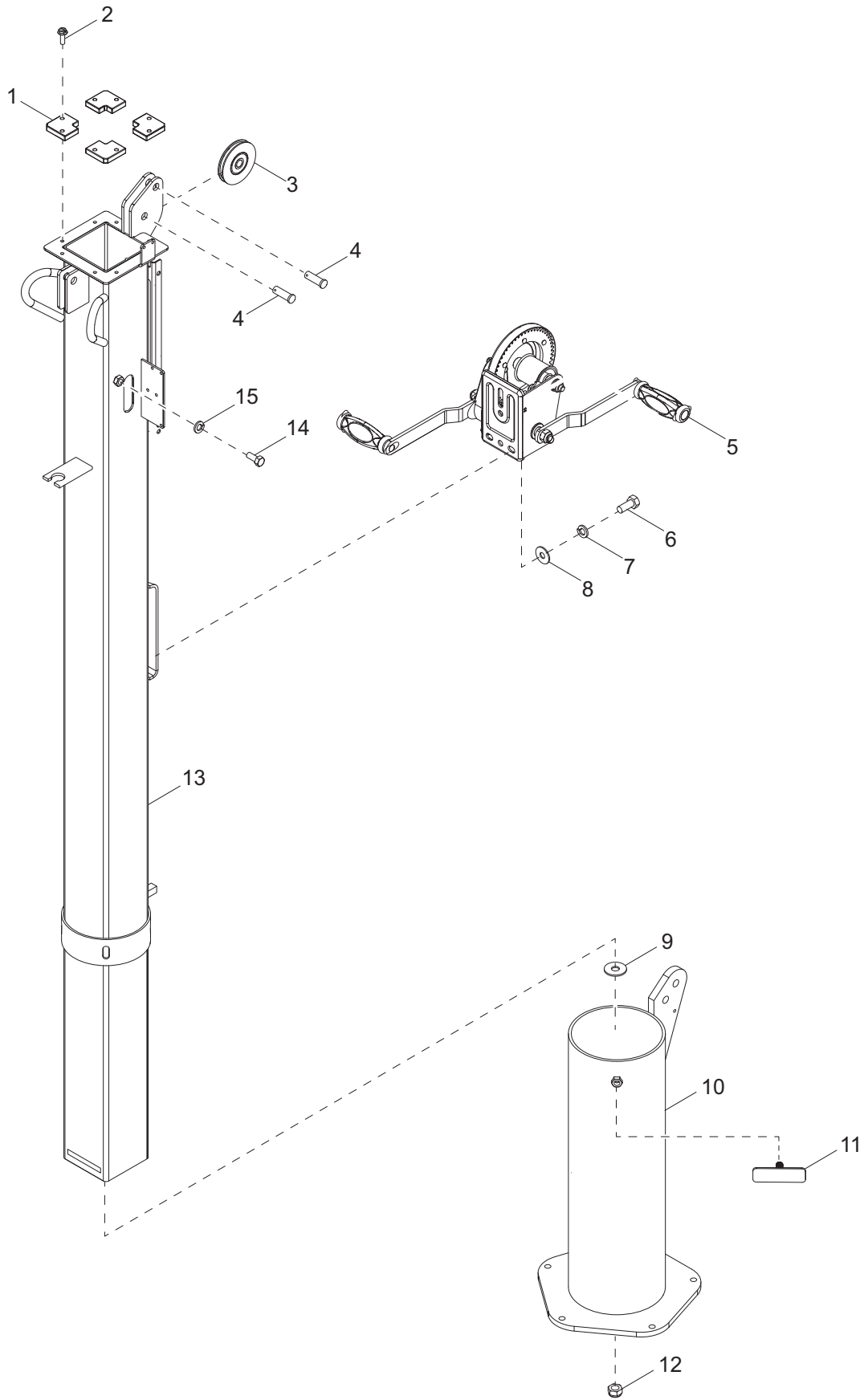

02579

## MAST ASSEMBLY - BOTTOM POST - MANUAL WINCH

Item	Part No.	Qty	Description	Notes
1	31225	4	Guide	
2	63358	8	Screw, .250-20 x .625 hex washer head	
3	33736	1	Assembly, pulley vertical mast	
4	63325	2	Pin, clevis .500 diameter x 1.063 UL	
5	72127	1	Winch, manual - 1500 lb, dual handle	
6	60205	3	Screw, .375-16 x 1.0 hex, G5	
7	60206	3	Washer, .375 split lock - hardened	
8	60386	3	Washer, .375 flat .993/.064	
9	60247	1	Washer, .750 flat 2.020/.130	
10	31218B	1	Weldment, mast rotation tube	
11	10000018317	1	Weldment, T-handle	
12	60584	1	Nut, .750-10 nylock, G5	
13	37462B	1	Weldment, mast 4.0 in	
14	62269	2	Screw, .375-16 x .75 hex, SS - red	
15	60703	2	Washer, .375 split lock, SS	





## MAST ASSEMBLY - BOTTOM POST - ELECTRIC WINCH

Item	Part No.	Qty	Description	Notes
1	63358	8	Screw, .250-20 x .625 hex washer head	
2	31225	4	Guide	
3	33736	1	Assembly, pulley vertical mast	
4	63325	2	Pin, clevis .500 diameter x 1.063 UL	
5	60207	11	Nut, 8-32 nylock, G6	
6	60269	18	Washer, #8 flat ..433/.036	
7	60703	2	Washer, .375 split lock, SS	
8	62269	2	Screw, .375-16 x .75 hex, SS - red	
9	31740	1	Assembly, down switch	
10	67190	4	Screw, 8-32 x 1.125 socket head, SS	
11	60247	1	Washer, .750 flat 2.020/.130	
12	10000018317	1	Weldment, T-handle	
13	60584	1	Nut, .750-10 nylock, G5	
14	31218B	1	Weldment, mast rotation tube	
15	37207B	1	Plate, contactor	
16	11293	1	Contactor	hardware included
17	60244	7	Screw, 8-32 x .750 pan Phillips, G2	
18	37468B	1	Weldment, winch cover	
19	60205	5	Screw, .375-16 x 1.0 standard hex, G5	
20	60206	5	Washer, .375 split lock	
21	60386	5	Washer, .375 flat .993/.064	
22	12874	1	Winch, electric - 770 lb hoist	
23	37462B	1	Weldment, mast 4.0 in	
24	37205B	1	Cover, up limit switch	
25	31739	1	Assembly, up stop switch	
--	12922	2	Boot, battery cable - red	
--	31742	1	Wire group, electric winch box	
--	31743	1	Harness, winch power cables	

# ENCLOSURE ASSEMBLY (1 OF 2)

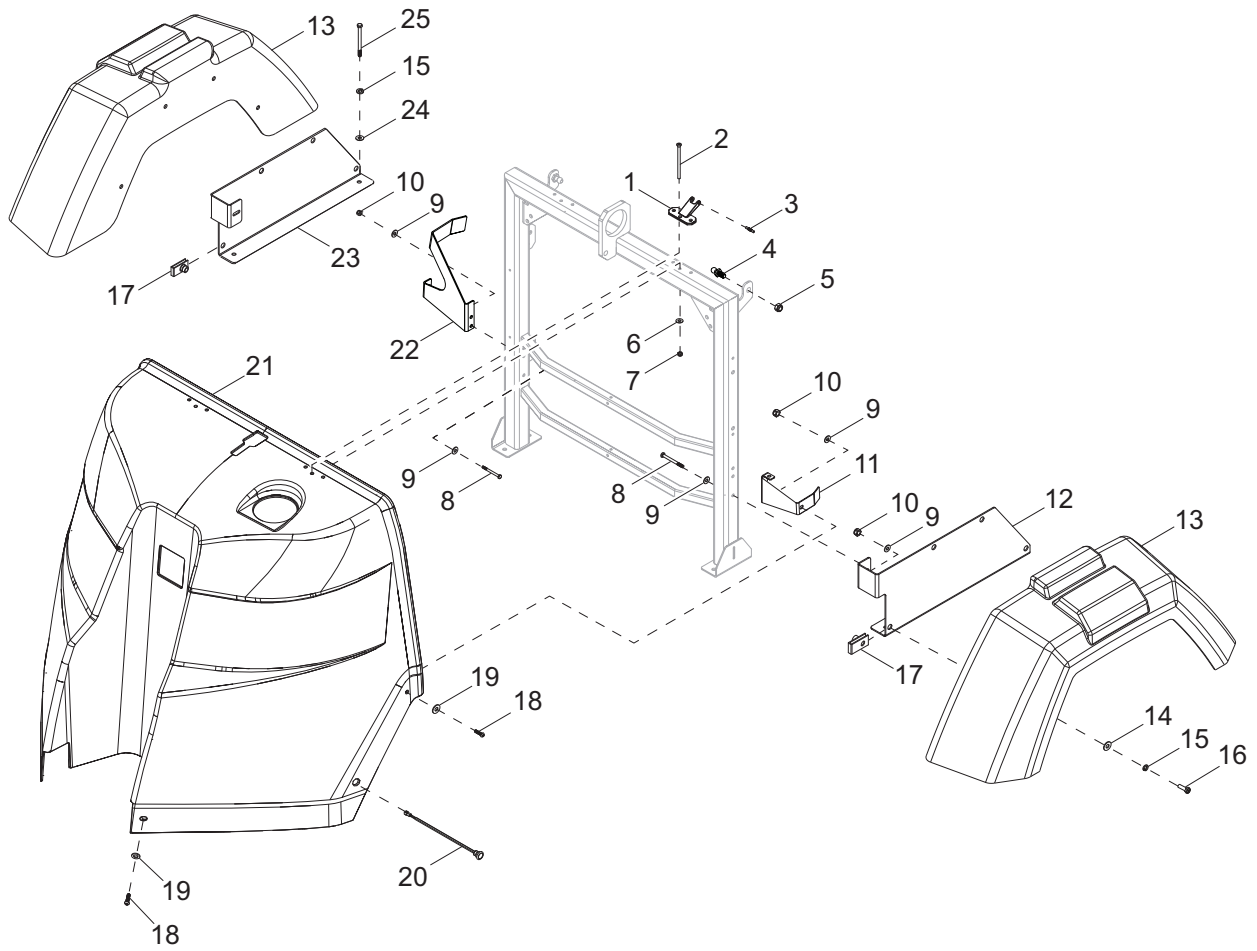

02435

**ENCLOSURE ASSEMBLY (1 OF 2)**

<b>Item</b>	<b>Part No.</b>	<b>Qty</b>	<b>Description</b>	<b>Notes</b>
1	10000022542	2	Hinge, offset housing leaf - front	
2	35282	6	Screw, 10-24 x 3.0 flat head Phillips, SS	
3	10000022543	2	Pin, offset housing hinge - knurled	
4	35293	2	Ball stud, 10mm, .312-18	
5	60303	2	Nut, .312-18 nylock, G2	
6	60237	12	Washer, #10 flat .495/.036	
7	60457	12	Nut, M6-1.0 weld, class 5	
8	61234	6	Screw, .250-20 x 2.750 standard hex, G5	
9	60243	12	Washer, .250 flat .735/.060	
10	60144	8	Nut, .250-20 nylock, G5	
11	10000017357	1	Guide bracket, enclosure meeting -LH	
12	35141B	1	Bracket, mounting fender - left	
13	10000017287	2	Fender, plastic, 13 in. wheel - textured black	
14	60386	8	Washer, .375 flat .993/.064	
15	60271	8	Washer, .312 split lock	
16	60028	8	Screw, .312-18 x 1.0 standard hex, G5	
17	62086	8	Nut, .312-18 U-clip - short type	
18	68070	4	Screw, .250-20 x 1.00 button hex, SS	
19	60696	6	Washer, .250 flat .625/.050, SS	
20	36961	2	Assembly, amber side marker light	
21	10000012656	1	Enclosure, front cover	
22	10000017378	1	Guide bracket, enclosure meeting -RH	
23	35216B	2	Bracket, mounting fender - right	
24	60119	6	Washer, .312 flat .875/.070	
25	60404	4	Screw, .312-18 x 1.250 standard hex, G5	

# ENCLOSURE ASSEMBLY (2 OF 2)

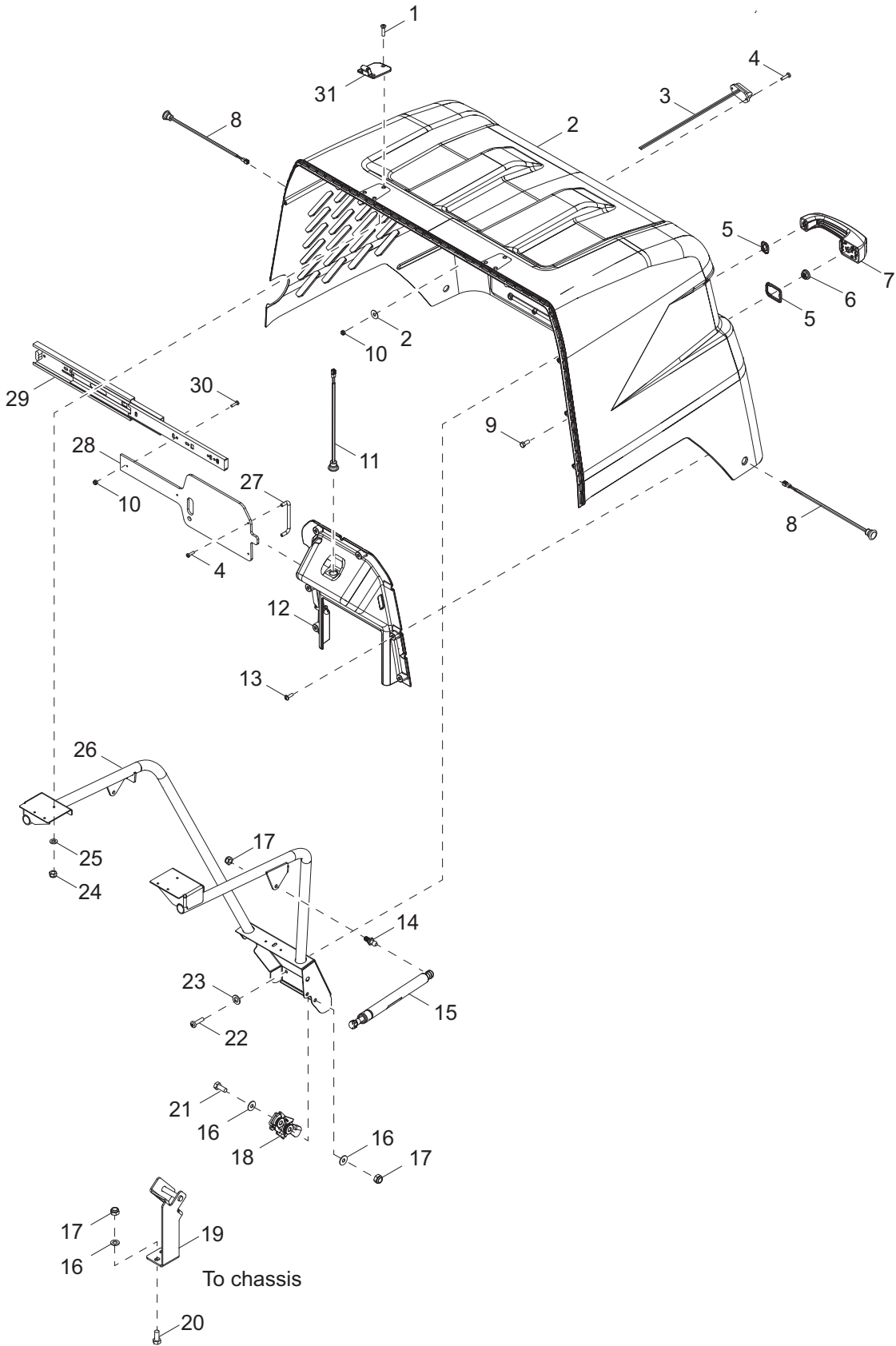

02436

## ENCLOSURE ASSEMBLY (2 OF 2)

Item	Part No.	Qty	Description	Notes
1	35290	6	Screw, 10-24 x 1.00 flat Phillips, SS	
2	10000012659	1	Housing, rear textured - CAT yellow	
3	36963	1	Assembly, license plate light	
4	60694	4	Screw, 8-32 x .750 pan Phillips, SS	
5	70216	1	Gasket, kit handle, push button	
6	60036	1	Nut, M6-1.00 serrated flange, G8.8	
7	35138	1	Handle, push-button padlock	
8	36962	2	Assembly, red side marker	
9	60335	1	Screw, M6-1.00 x 25 standard hex, SS	
10	60270	4	Nut, 8-32 nylock, class 6	
11	36964	1	Assembly, controls light	
12	10000012596	1	Bezel, control panel textured - black	
13	10000017348	6	Screw, D60-2.14 x 20TRWH	
14	35293	2	Ball stud, 10mm, .313-18	
15	35137	2	Gas shock, 120 lb	
16	60119	6	Washer, .312 flat .875/.070	
17	60303	6	Nut, .312-18 nylock, G2	
18	35139	1	Latch, rotary	
19	37178B	1	Mount, door latch striker	
20	61066	2	Screw, .312-18 x 1.00 carriage square - SS	
21	62001	2	Screw, .312-18 x 1.250 standard hex, G5	
22	60146	3	Screw,	
23	60243	3	Washer, .250 flat .735/.060	
24	60457	6	Nut, 10-24 nylock, G2 ZC	
25	60237	2	Washer, #10 flat .495/.036 ZC	
26	37012B	1	Weldment, enclosure structure	
27	37123	1	Handle, control box cover	
28	10000017623	1	Cover, sliding control panel	
29	36914	1	Slide, control box cover	
30	62054	2	Screw, 8-32 x .500 pan Phillips - SS	
31	10000022523	2	Hinge, leaf offset housing - rear	
--	60335	1	Screw, M6-1.00 x 25 standard hex, SS	
--	60375	1	Clamp, tubing - .312 lt duty	

# CONTROL BOX ASSEMBLY

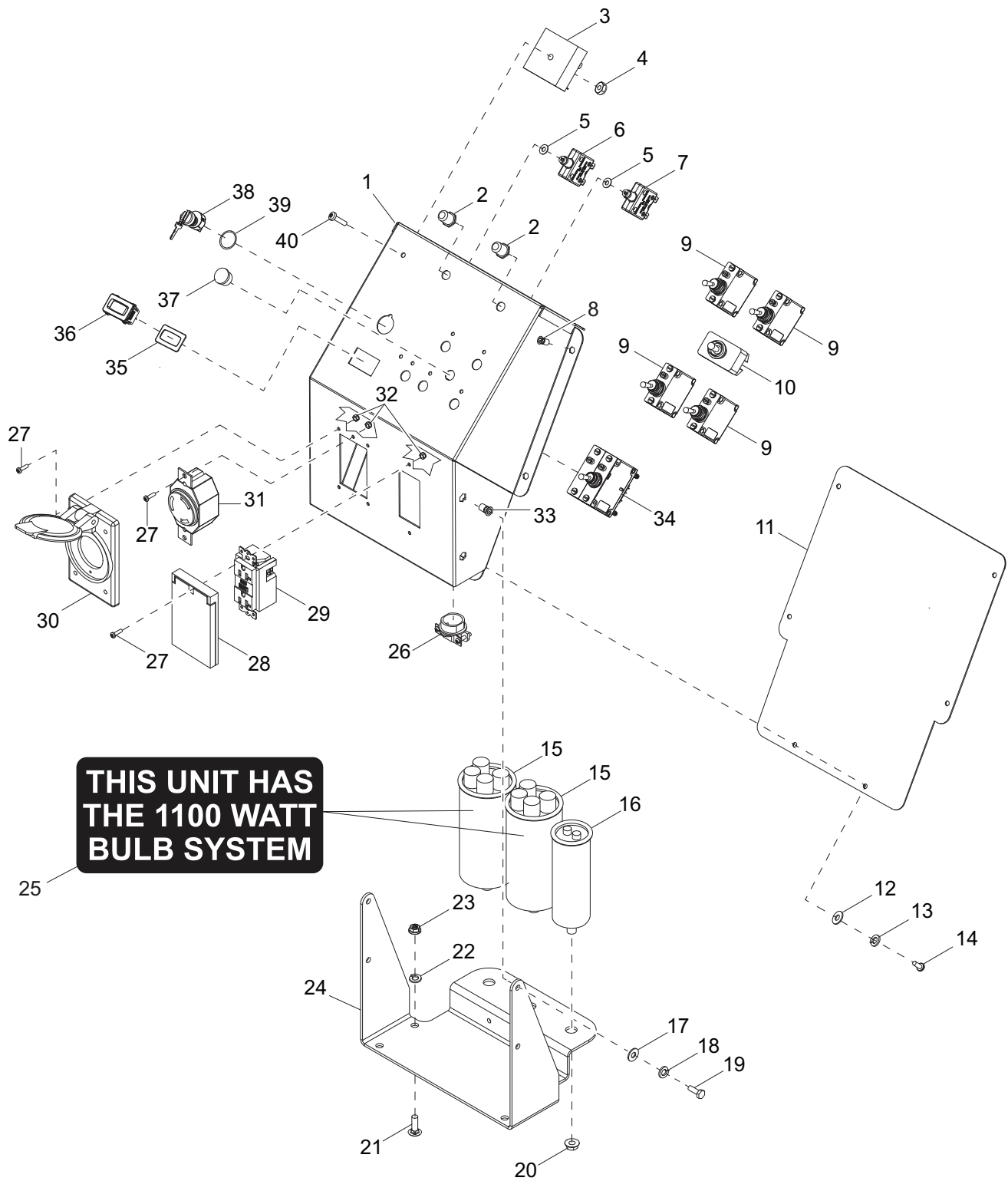

02584

## CONTROL BOX ASSEMBLY

Item	Part No.	Qty	Description	Notes
1	36884B	1	Control box	
2	36938	2	Boot, push button breaker	
3	14201	1	Relay, 10A SPDT, time delay - 15 sec fixed	
4	60061	5	Nut, 10-32 nylock	
5	60386	2	Washer, .375 flat .993/.064	
6	36937	1	Breaker, 10A DC	
7	36935	1	Breaker, 15A, 1 pole, 250V	
8	62234	6	Insert, threaded #10-32 hex .020-.130 grip	
9	36880	4	Switch, light - 15A	
10	65707	1	Switch, toggle - SPDT spring	Electric mast only
11	36885B	1	Cover, control panel box	
12	60237	6	Washer, #10 flat .495/0.36	
13	60252	6	Washer, #10 split lock	
14	62254	6	Screw, 10-32 x .500 serrated flange, SS	
15	10000024477	2	Capacitor, dual 24 $\mu$ F/24 $\mu$ F 5% 540VAC stud mount	
16	36980	1	Capacitor, 25 $\mu$ F, 5% 440VAC, sealed stud mount	
17	60243	4	Washer, .250 flat .735/.060	
18	60286	4	Washer, .250 split lock	
19	60281	4	Screw, .250-20 x .750 standard hex, G5	
20	60148	3	Nut, M12-1.75 serrated flange, G8.8	
21	61066	4	Screw, .312-18 x 1.0 carriage, SS	
22	60119	4	Washer, .312 flat .875/.070	
23	60095	4	Nut, .312-18 serrated flange	
24	36911B	1	Bracket, control box mounting	
25	10000030392	2	Decal, 1100W bulb system	
26	14219	1	Strain relief - .75 Romex w/nut	
27	62210	6	Screw, 6-32 x .50 pan Phillips, SS	
28	37017	1	Cover receptacle - weather proof, 20A GFCI single	
29	14130	1	Receptacle, 120V/20A GFI	
30	36939	1	Cover, receptacle - weather proof 20/30A twist-lock	
31	14137	1	Receptacle, 240V/30A twist	
32	60728	6	Nut, 6-32 nylock	
33	63231	4	Insert, threaded .250-20 hex .027-.165 grip	
34	36975	1	Breaker, 30A main	
35	36944	1	Gasket, hour meter	
36	36886	1	Meter, hour	
37	65798	1	Plug	Manual mast only
38	36882	1	Switch, sealed key, 4-position	
39	37042	1	O-ring, .75IDx15-16 in. x 3/32 in	
40	63308	1	Screw, 10-32 x 1.250 pan Phillips, SS	
--	68282	1	Wire group, control box - electric mast	
--	68283	1	Harness, generator to control box	
--	68284	1	Harness, control box to electric mast	

# CONTROL BOX ASSEMBLY - POWERZONE OPTION (1 OF 2)

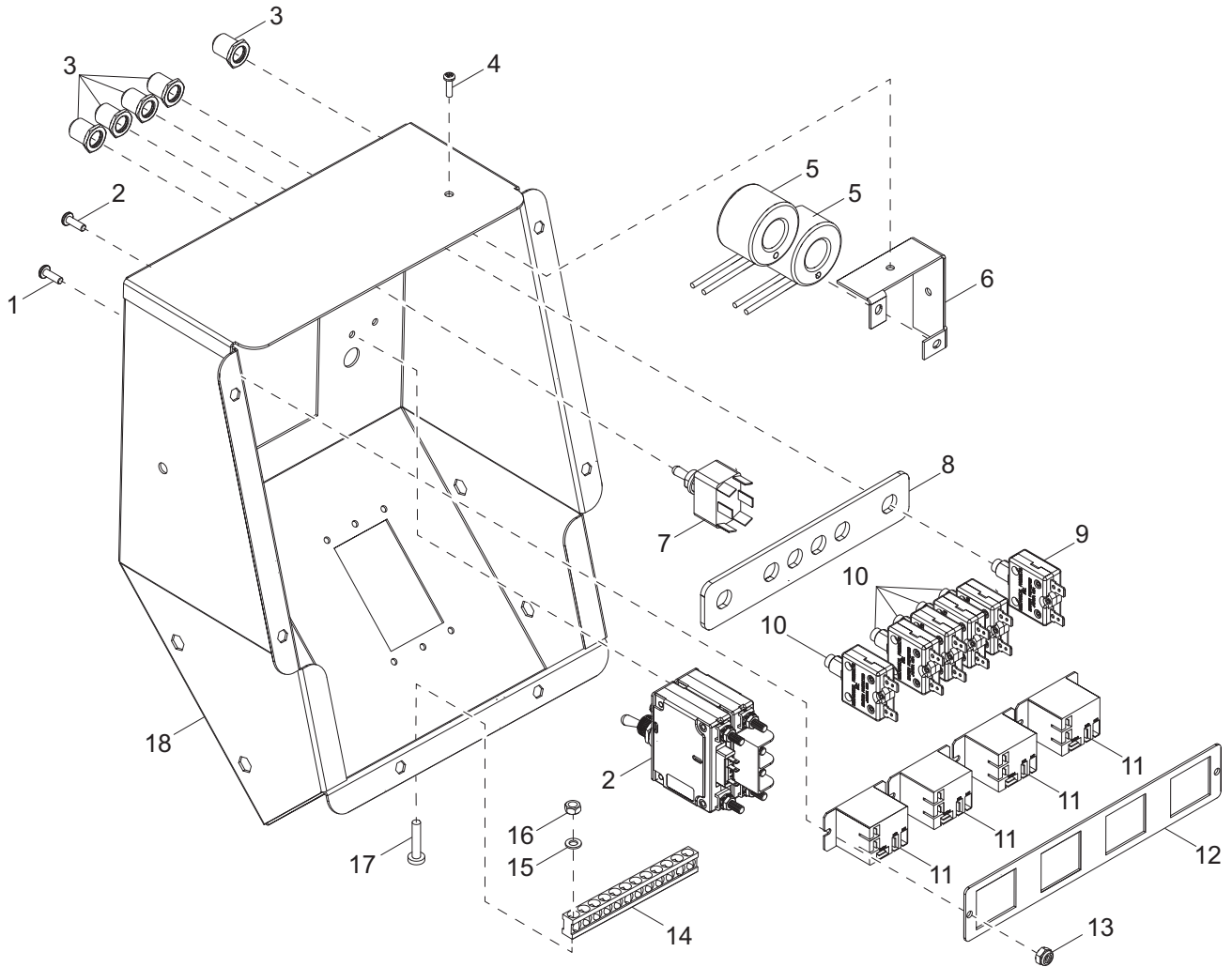

02345



## CONTROL BOX ASSEMBLY - POWERZONE OPTION (1 OF 2)

Item	Part No.	Qty	Description	Notes
1	62054	3	Screw, 8-32 x .500 pan Phillips,- SS	
2	36975	2	Breaker, 30A main	with hardware
3	36938	6	Boot, push button breaker	
4	62210	6	Screw, 6-32 x .50 pan Phillips - SS	
5	66255	2	Transformer, current	
6	38449B	1	Bracket, CT mount	
7	68508	1	Switch, toggle - SPST (on-off) 12A 125V	
8	38448B	1	Spacer, breaker control box	
9	36937	1	Breaker, 10A DC	
10	36935	5	Breaker, 15A, 250V, 1 pole	
11	29759	4	Relay, 12V coil 120-240 VAC rated	
12	38447B	1	Bracket, relay	
13	60270	3	Nut, 8-32 nylock, G6	
14	14204	1	Kit, ground bar	
15	60252	6	Washer, #10 split lock	
16	60318	2	Nut, 8-32 Hex, G5	
17	60406	2	Screw, 8-32 x 1.0 pan Phillips, G2	
18	37823B	1	Box, control - Powerzone	

# CONTROL BOX ASSEMBLY - POWERZONE OPTION (2 OF 2)

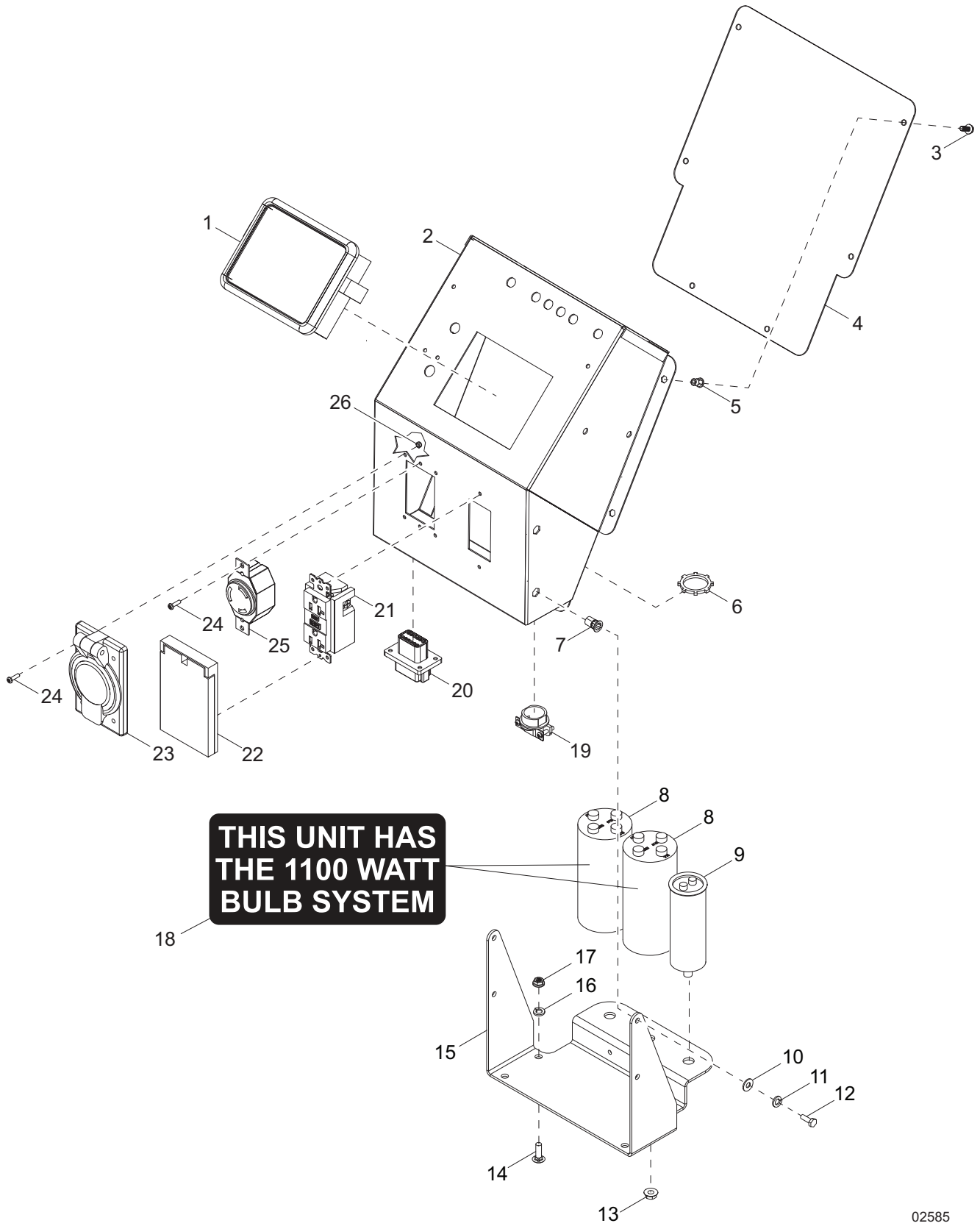

02585

## CONTROL BOX ASSEMBLY - POWERZONE OPTION (2 OF 2)

Item	Part No.	Qty	Description	Notes
1	70137	1	Controller, Deep Sea - programmed	
2	37823B	1	Box, PZ control panel	
3	60277	6	Screw, 10-32 x .500 pan Phillips, G2	
4	38413B	1	Cover, control panel box	
5	62234	6	Insert, 10-32 hex, .020-.130 grip, threaded	
6	16300	2	Nut, .750 Romex strain relief	
7	63231	4	Insert, .250-20 hex, .027-.165 grip, threaded	
8	10000024477	2	Capacitor, dual 24 $\mu$ F/24 $\mu$ F 5% 540VAC stud mount	
9	36980	1	Capacitor, 25 $\mu$ F 5% 440VAC, sealed stud mount	
10	60243	4	Washer, .250 flat .735/.060	
11	60286	4	Washer, .250 split lock	
12	60647	4	Screw, .250-20 x .500 hex, G5	
13	60148	3	Nut, M12-1.75 serrated flange, G8.8	
14	61066	4	Screw, .312-18 x 1.0 carriage - SS	
15	38409B	1	Bracket, control box mounting	
16	60119	4	Washer, .312 flat .875/.070	
17	60095	4	Nut, .312-18 serrated flange - case hardened	
18	10000030392	2	Decal, 1100W bulb system	
19	14219	2	Strain relief, .75 Romex w/nut	
20	66695	1	Connector, Duetsch 12 position - flange DT	
21	14130	1	Receptacle, 120V/20A GFI	
22	37017	1	Cover, receptacle 20A GFCI single - weatherproof	
23	36939	1	Cover, receptacle 20/30A - weatherproof	
24	62210	6	Screw, 8-32 x .500 pan Phillips - SS	
25	14137	1	Receptacle, 250V/ 30A twist	
26	60728	6	Nut, 6-32 nylock, G5	
--	68534	1	Harness, control box PZ	replaces p/n 68284
--	68535	1	Harness, gen to control box PZ	replaces p/n 68283
--	69654	1	Harness, engine PZ	replaces p/n 37034

# COOLING SYSTEM ASSEMBLY

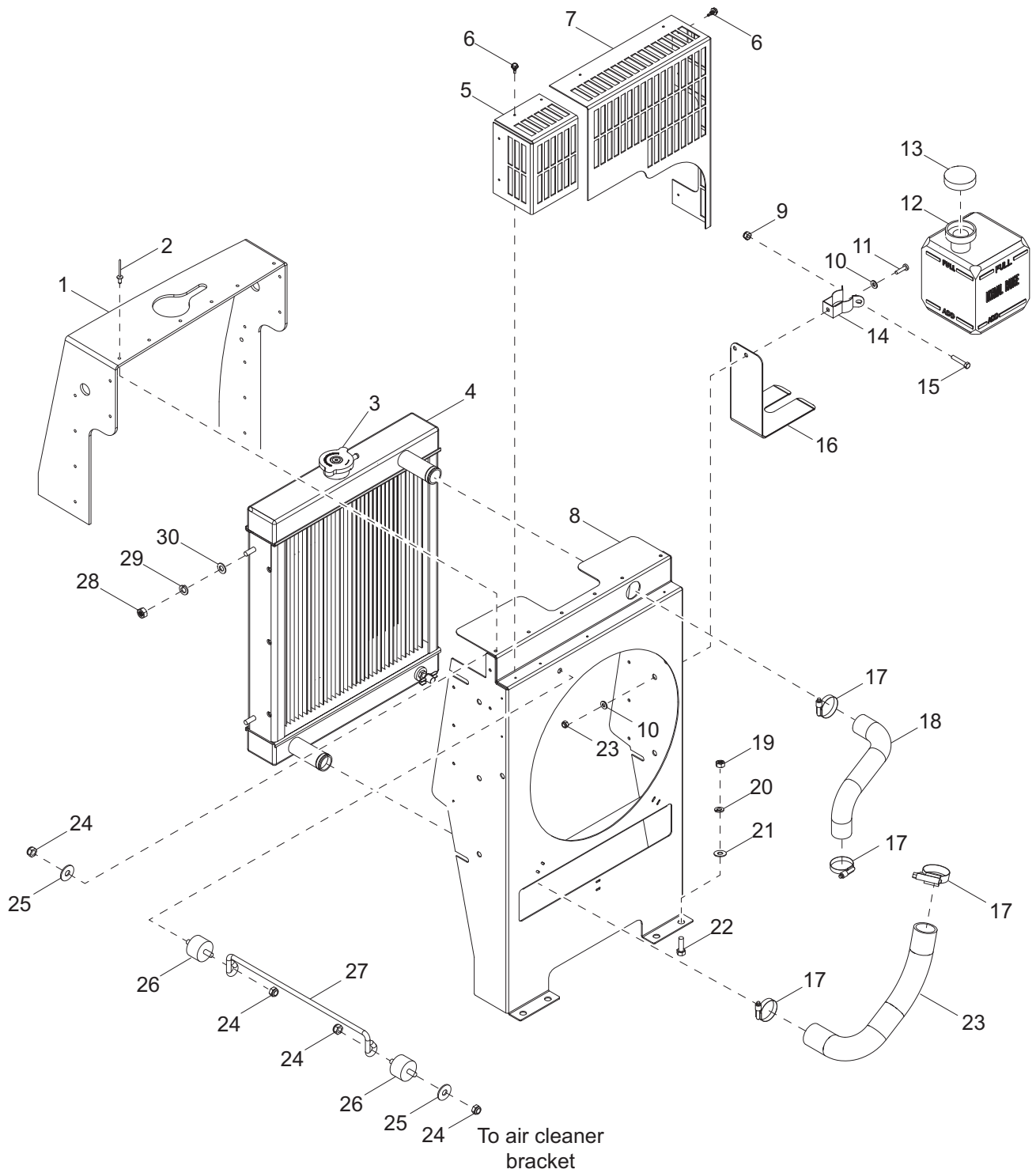

02451

## COOLING SYSTEM ASSEMBLY

Item	Part No.	Qty	Description	Notes
1	36979	1	Seal, rubber, cooling	
2	60195	18	Rivet, .188 dia. x .375 to .500 grip, large flange	
3	19219	1	Cap, radiator pressure small - 14.7 psi	
4	10000020162	1	Radiator	
5	36227B	1	Guard, fan, left	
6	60364	9	Screw, 10-16x5.0 std hex, G2	
7	72161B	1	Guard, fan, right	
8	21321B	1	Fan shroud	
9	60144	1	Nut, .250-20 nylock, G5	
10	60067	4	Washer, #10 flat .435/.060, SS	
11	61180	2	Screw, 10-32 x .750 pan Phillips, SS	
12	20287	1	Jug, overflow 2 qt. (.5 gal)	
13	19714	1	Cap, overflow jug	
14	19726	1	Clamp, overflow bottle	
15	60414	1	Screw, .250-20 x 1.50 standard hex, G5	
16	22419B	1	Bracket, support overflow jug .5 gallon	
17	15422	4	Clamp, hose - SAE 020 (.75-1.75)	
18	31543	1	Hose, radiator - upper	
19	60285	14	Nut .312-18 hex, G2	
20	60271	21	Washer, .312 split lock	
21	60119	24	Washer .312 flat .875/.070	
22	61066	4	Screw, .312-18 x 1.00 carriage 18-8 SS	
23	31542	1	Hose, radiator - lower	
24	62079	4	Nut, .312-18 nylock jam	
25	60119	2	Washer, .312 flat .875/.070	
26	34052	2	Isolator, rubber 1.50 x 1.0, 5/16-18 studs	
27	36989	1	Rod, radiator stay	
28	60032	4	Nut, M8-1.25 hex, G8.8	
29	60029	2	Washer, M8 split lock	
30	60166	2	Washer, M8 flat	

# ENGINE ASSEMBLY (1 OF 2)

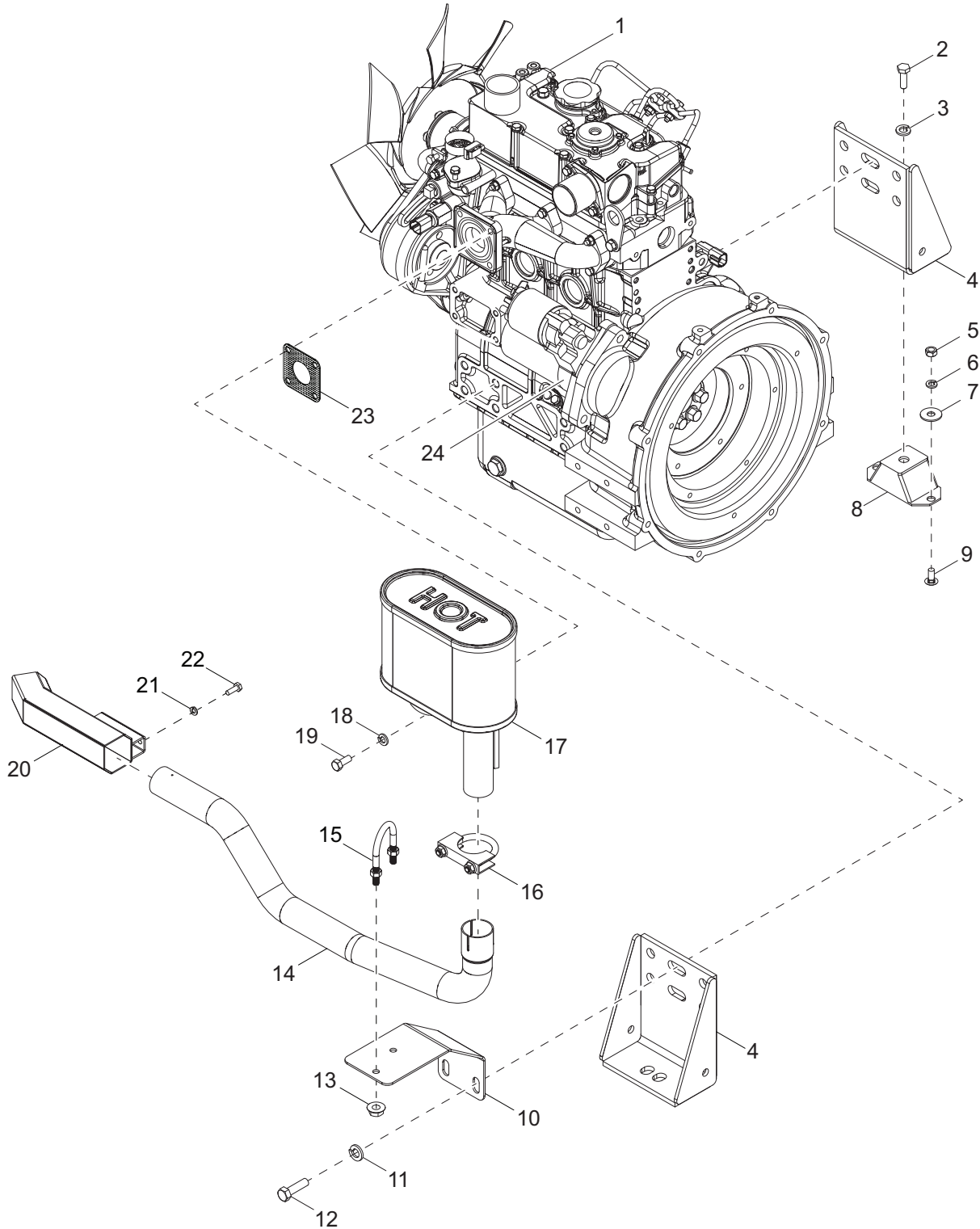

02452

## ENGINE ASSEMBLY (1 OF 2)

Item	Part No.	Qty	Description	Notes
1	73190	1	Engine, Caterpillar C1.1, TF4	
2	60275	4	Screw, .500-13 x 1.0 hex, G5	
3	60702	4	Washer, .500 split lock, SS	
4	12058B	2	Weldment, engine mount	
5	60285	4	Nut, .312-18 hex, G2	
6	60271	4	Washer, .312 split lock	
7	60119	4	Washer, .312 flat .875/.070	
8	15241	2	Isolator, 80-200 lbs - 2 inch WD	
9	61066	4	Screw, .312-18 x 1.0 carriage, SS	
10	10000025229	1	Bracket, side exhaust	
11	60026	8	Washer, M10 split lock	
12	60422	8	Screw, M10-1.25 x 25 standard hex, G8.8	
13	60095	2	Nut, .312-18 serrated flange	
14	10000024188	1	Pipe, side exhaust	
15	61235	1	U-bolt, .312-18 x 2.688 x 2.063	
16	68082	1	Clamp, muffler - 1.63	
17	17426	1	Muffler	
18	60029	4	Washer, M8 split lock	
19	60165	4	Screw, M8-1.250 x 16 hex, G10.9	
20	76924B	1	Shield, exhaust	
21	60286	2	Washer, .250 split lock	
22	60281	2	Screw, .250-20 x .750 standard hex, G5	
23	11042SRV	1	Gasket, muffler	
24	39843	1	Starter	
--	75007	1	Harness, main	

**Note:** Engine and generator parts used in all Generac Mobile Products, LLC equipment carry the Original Equipment Manufacturer (OEM) warranty unless otherwise stated. OEM warranty parts must be purchased through an OEM dealer. Please contact Generac Mobile Products, LLC with questions.

# ENGINE ASSEMBLY (2 OF 2)

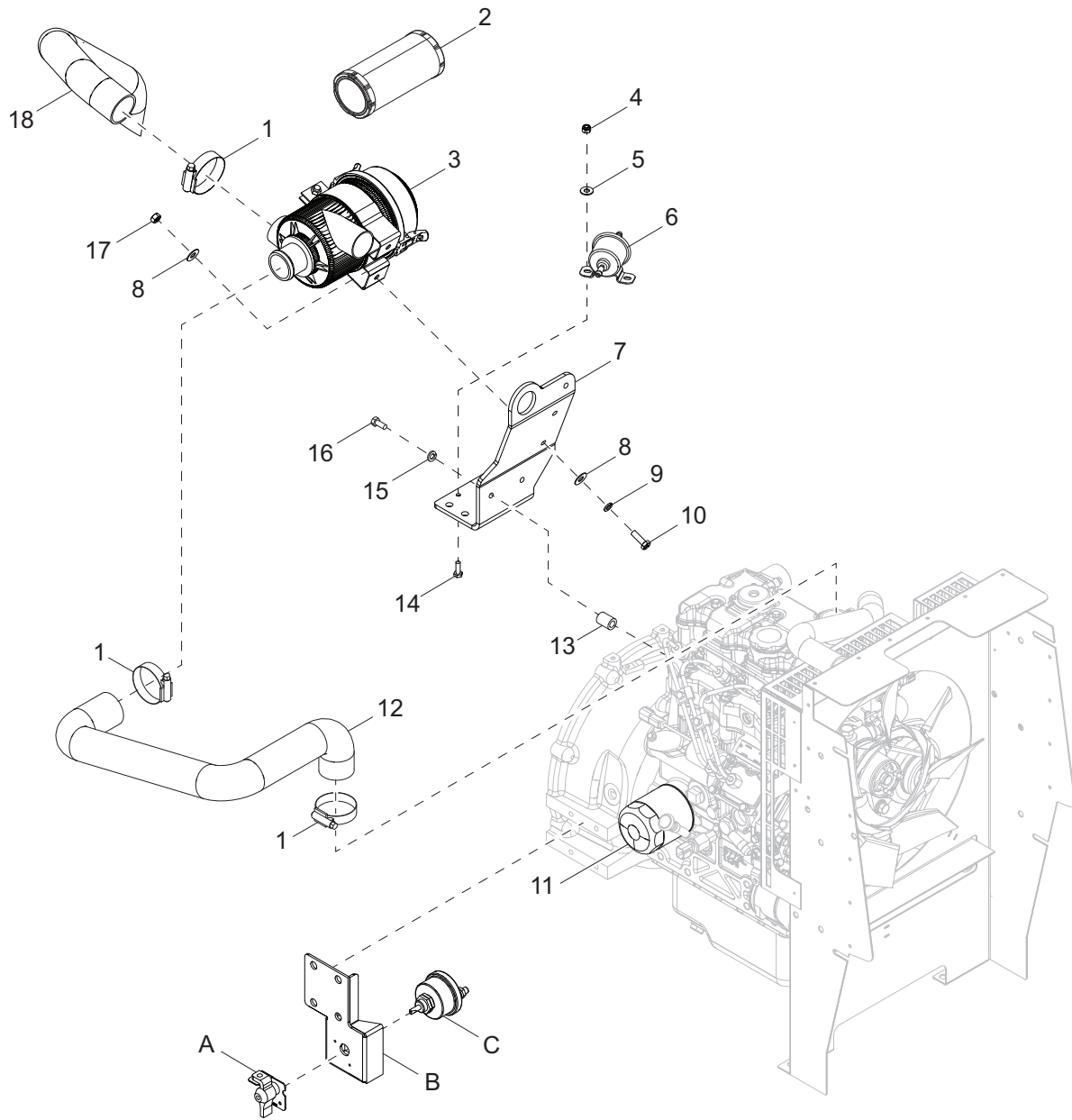

02453



## ENGINE ASSEMBLY (2 OF 2)

Item	Part No.	Qty	Description	Notes
1	60316	3	Clamp, hose - SAE 032 (1.56-2.50)	
2	16444	1	Element, air filter	
3	34066	1	Filter, air, w bracket	incl. 16444
4	60144	2	Nut, .250-20 nylock, G5	
5	60243	2	Washer, .250 flat .735/.060	
6	12994	1	Fuel pump, electric	
7	17062B	1	Bracket, air cleaner	
8	60119	6	Washer, .312 flat .875/.070	
9	60271	4	Washer, .312 split lock	
10	60028	2	Screw, .312-18 x 1.00 standard hex, G5	
11	39842	1	Filter, oil	
12	31541	1	Hose, air	
13	41235ZY	2	Spacer, .750OD x .44ID x 1.0 long	
14	60281	2	Screw, .250-20 x .750 standard hex, G5	
15	60206	2	Washer, .375 split lock - hardened	
16	65719	2	Screw, M8-1.25 x 45 standard hex, G10.9	
17	60285	4	Nut, .312-18 hex, G2	
18	10434	1	Hose, air intake	

*Battery Disconnect: If equipped*

A	65499	1	Switch lockout lever kit
B	10000008538	1	Bracket, battery disconnect
C	65498	1	Switch, disconnect

**Note:** Engine and generator parts used in all Generac Mobile Products, LLC equipment carry the Original Equipment Manufacturer (OEM) warranty unless otherwise stated. OEM warranty parts must be purchased through an OEM dealer. Please contact Generac Mobile Products, LLC with questions.

# GENERATOR ASSEMBLY

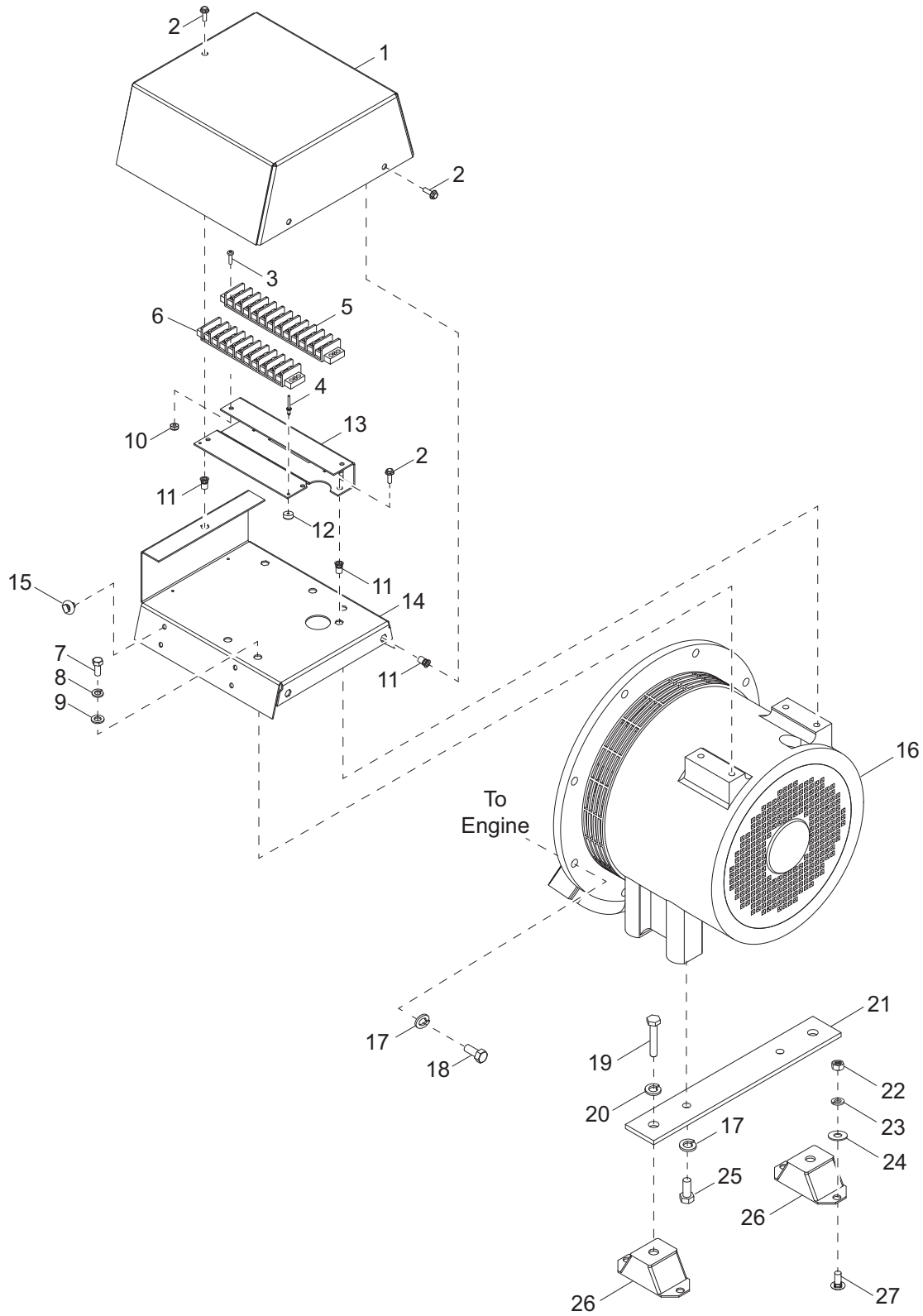

02442

## GENERATOR ASSEMBLY

Item	Part No.	Qty	Description	Notes
1	17994B	1	Cover, generator, Marathon	
2	60175	5	Screw, .250-20x.500 serrated flange hex, G5	
3	60062	4	Screw, 10-32 x .750 pan Phillips, G2	
4	60267	2	Rivet, .125 dia x .191 to .270 grip	
5	14139	1	Block terminal - 12 position	
6	14203	1	Block terminal - 10 position	
7	61082	4	Screw, M8-1.25 x 20 serrated flange hex	
8	60271	4	Washer, .312 split lock	
9	60243	4	Washer, .250 flat .735/.060	
10	60061	4	Nut, 10-32 nylock	
11	63231	9	Insert, threaded .250-20 hex .027-.165 grip	
12	15215	2	Rubber bumper	
13	36942B	1	Bracket, terminal strip	
14	54254B	1	Plate, electric junction	
15	66685	8	Mount cable tie, fir tree, .25-.28 dia,.031-.276 grip	
16	10000020581	1	Generator, Marathon, 6kW, 60Hz, cap	
17	60206	8	Washer, .375 split lock	
18	60352	8	Screw, .375-16x1.250 standard hex, G5	
19	60275	2	Screw, .500-13 x 1.00 standard hex, G5	
20	60702	2	Washer, .500 split lock, SS	
21	15045B	1	Bracket, generator mounting	
22	60285	4	Nut, .312-18 hex, G2	
23	60271	4	Washer, .312 split lock	
24	60119	4	Washer, .312 flat .875/.070	
25	60352	2	Screw, .375-16 x 1.250 standard hex, G5	
26	15241	2	Isolator, rubber - 80-200 lb	
27	61066	4	Screw, .312-18 x 1.00 carriage, SS	
--	60168	6	Screw, .312-18 x .750 standard hex, G5	For flex plate mount
--	60166	18	Washer, M8 flat DIN 125 hardened	3 each w/60168

**Note:** Engine and generator parts used in all Generac Mobile Products, LLC equipment carry the Original Equipment Manufacturer (OEM) warranty unless otherwise stated. OEM warranty parts must be purchased through an OEM dealer. Please contact Generac Mobile Products, LLC with questions.

# COMPONENTS TO TRAILER ASSEMBLY

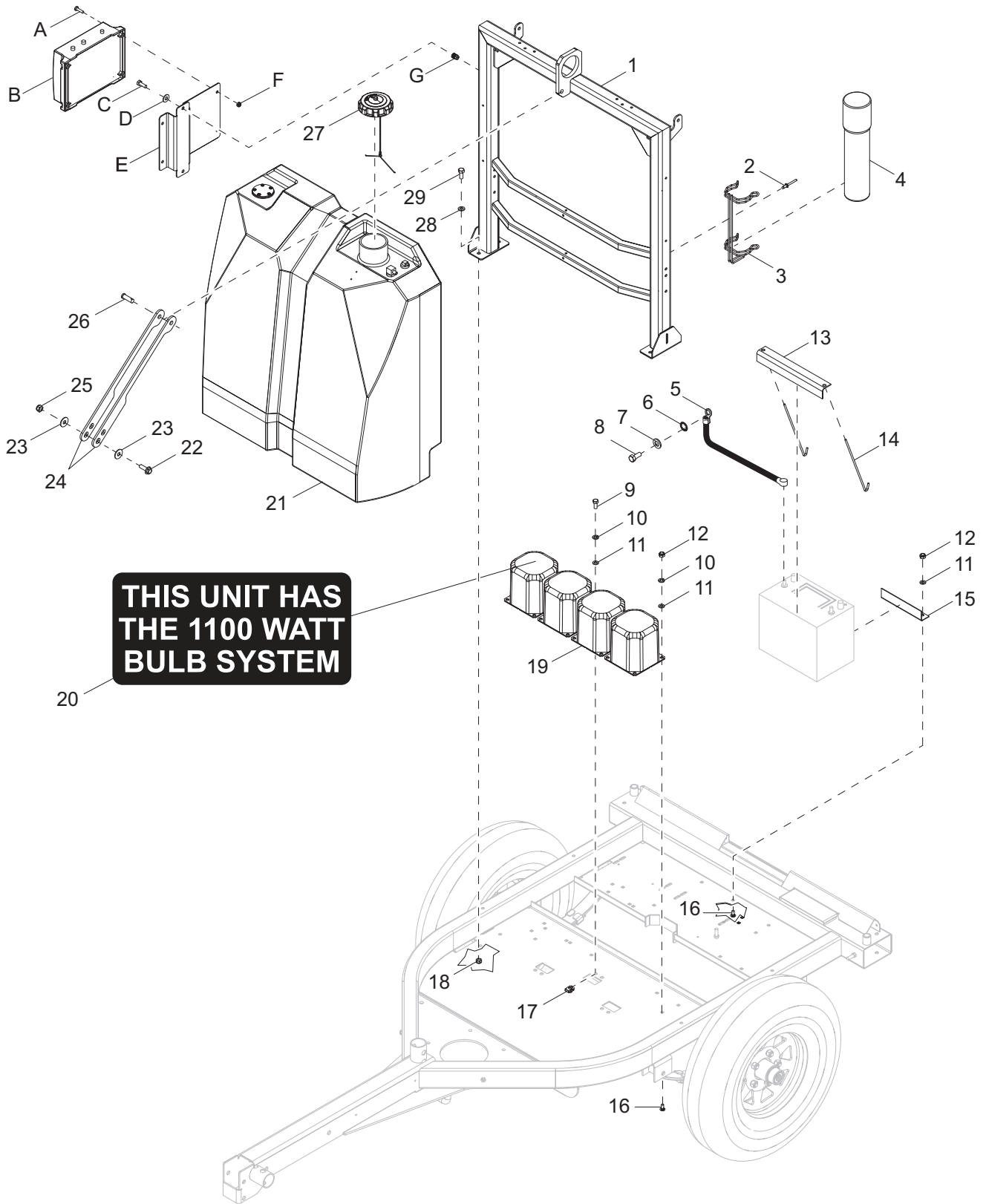

02454

## COMPONENTS TO TRAILER ASSEMBLY

Item	Part No.	Qty	Description	Notes
1	10000023283	1	Weldment, lift support	
2	60195	2	Rivet, .188 dia. x .375 to .500 grip	
3	11222	1	Bracket, manual holder	
4	11121	1	Manual holder tube, black 14 inch	
5	10699	1	Cable, battery - 24" 4GA , .375 lug, black	
6	60747	1	Washer, .375 internal star	
7	60026	1	Washer, M10 split lock	
8	60495	1	Screw, M10-1.25 x 16 hex, G8.8	
9	60028	6	Screw, .312-18 x 1.0 standard hex, G5	
10	60271	8	Washer, .312 split lock	
11	60119	8	Washer, .312 flat .875/.07	
12	60285	3	Nut, .312-18 hex, G2	
13	12924B	1	Angle, battery hold-down	
14	60820	2	Bolt, J - .250-20 x 9.0	
15	17992B	1	Bracket, battery stop	
16	61066	3	Screw, .312-18 x 1.0 carriage, SS	
17	62086	6	Nut, .312-18 U-clip, short-type	
18	60358	4	Nut, .375-16 nylock, G5	
19	10000029380	4	Assembly, transformer - can and base - 60Hz-MH	
20	10000030392	4	Decal, 1100W bulb system	
21	69919	1	Tank, fuel - 42 gal with sending unit	
22	60484	2	Screw, .500-13 x 2.0 standard hex, G5	
23	60309	4	Washer, .500 flat 1.060/.090	
24	39660B	2	Bar, chassis support	
25	62221	2	Nut, .500-13 nylock, G5	
26	63325	1	Pin, clevis - .500 dia. x 1.063 UL, ZP	
27	16326	1	Cap, fuel, 3.5 dia., diesel, vent w/tether	
28	60386	4	Washer, .375 flat .993-.064	
29	60352	4	Screw, .375-16 x 1.250 standard hex, G5	
--	50018	5 ft	Hose, fuel - .312 ID, 50 psi, SAE 30R7	
--	60777	2	Clamp, hose - .312 fuel hose, crimp style	
--	14211	4.25 ft	Hose, fuel - .188, 50 psi, SAE 30R7	
--	60778	2	Clamp, hose - .188 fuel hose, crimp style	

*Battery Charger: If equipped*

A	60062	4	Screw, 10-32 x .750 pan Phillips, G2
B	66212	1	Charger, battery 2-5A/1-10A, 3 stage, 2 output
C	60281	2	Screw, .250-20 x .750 hex, G5
D	60243	2	Washer, .250 flat .735/.060
E	73218B	1	Bracket, battery charger
F	60415	4	Nut, 10-32 nylock
G	63132	2	Insert, .250-20 splined, .027-.165

# TRAILER ASSEMBLY

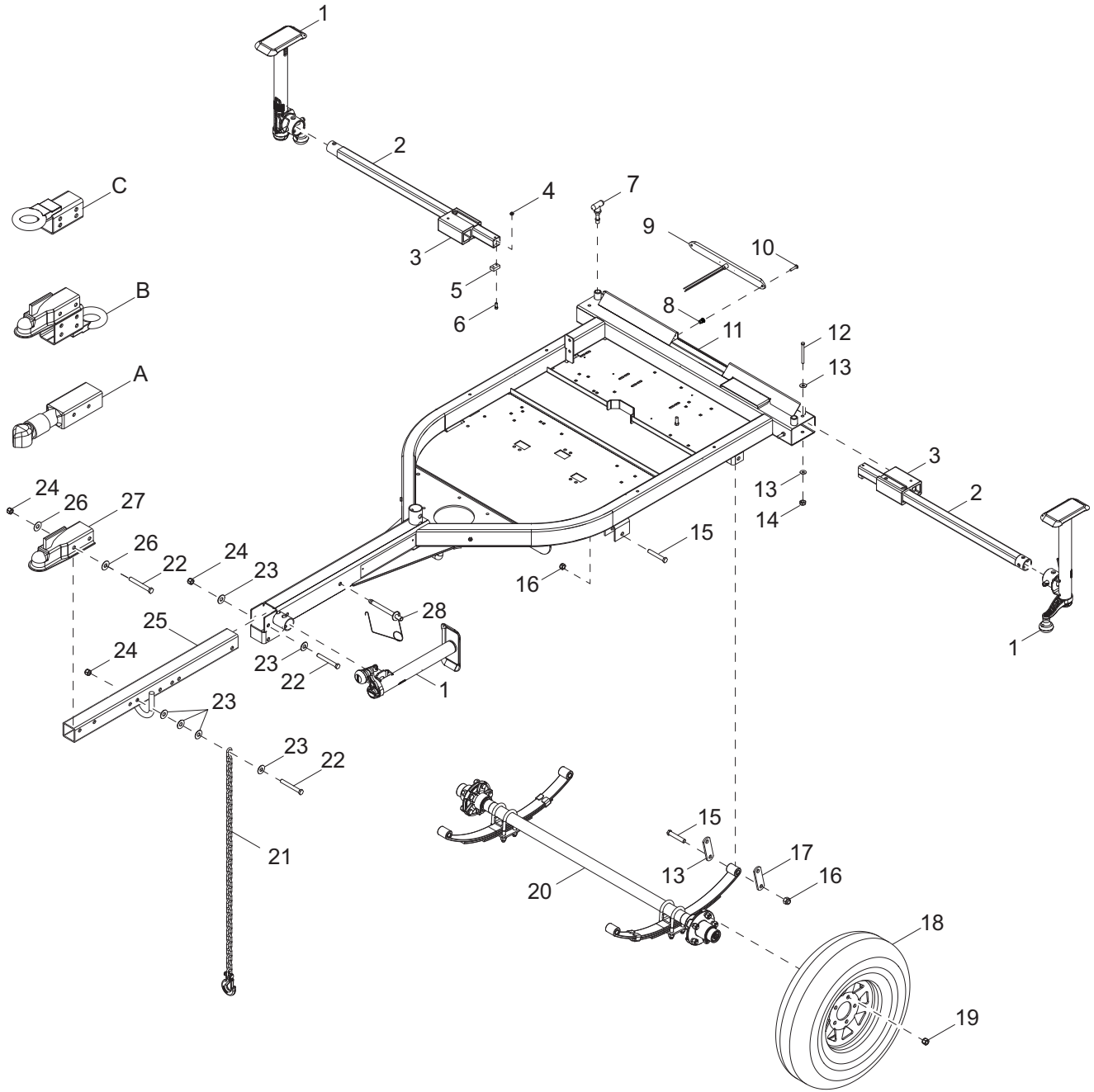

02444

## TRAILER ASSEMBLY

Item	Part No.	Qty	Description	Notes
1	72126	3	Jack, top wind - 1200 lb, tube mounted	
2	70230ZY	2	Weldment, outrigger tube	
3	36869	2	Guide block (molded) - outrigger	
4	60144	4	Nut, .250-20 nylock, G5	
5	72128	2	Pad/stop, wear - outrigger	
6	73196	4	Screw, .250-20 x 2.25 socket head	
7	36890	3	Spring pin, handle	
8	73092	4	Insert, #8-32 .020-.080 grip - close sealed	
9	36960	2	Assembly, tail light	
10	60694	4	Screw, 8-32 x .750 pan Phillips	
11	10000021817	1	Weldment, lt chassis	
12	60404	2	Screw, .312-18 x 4.00 standard hex, G5	
13	60119	4	Washer, .312 flat .875/.070	
14	60303	2	Nut, .312-18, nylock, G2	
15	60503	6	Screw, shackle, .562-18 x 3.00 standard hex, G5	
16	60504	6	Nut, .562-18 lock hex, G5	
17	19637	4	Plate, shackle bracket - 3.125"	
18	15976B	2	Wheel, ST175/8013 - 1360 lb	
19	60096	10	Nut, .500-20 lug, G5	
20	34760	1	Axle, 2200lb 47TC 35SC	
21	23367	2	Chain, safety - 7800 lbs rated	
22	50215	5	Screw, .500-13 x 4.00 standard hex, G5	
23	60416	10	Washer, .500 flat 1.375/.090	
24	62221	5	Nut, .500-13 nylock, G5	
25	17969B	1	Weldment, tilt tongue	
26	60309	4	Washer, .500 flat 1.060/.090	
27	16830	1	Coupler, 2.00 ball/2.50 channel	
28	33943	2	Pin, locking .500 x 3.50	
--	68348	1	Harness, trailer wiring, tandem tow	
--	68324	1	Harness, trailer enclosure front	
--	10000020727	1	Assembly, harness extension loomed	

*Hitch Options: If equipped*

A	13003B	1	Coupler, 2.00 ball/3.00 channel, Bulldog
B	34792ZC	1	Weldment, combination hitch - 2.50 tongue
C	16835B	1	Weldment, lunette ring 3.00 ID - 2.50 tongue
--	65548	1	Adapter, 4 pin flat to 4 pin flat x 12.00

# RECOMMENDED SPARE PARTS - ENGINE

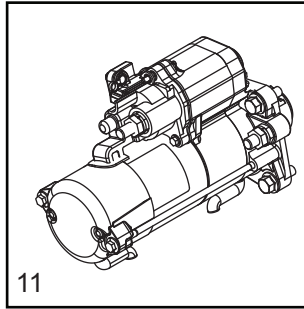
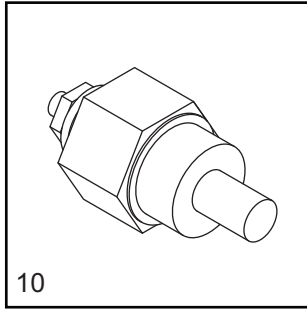
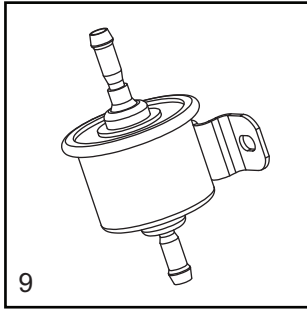
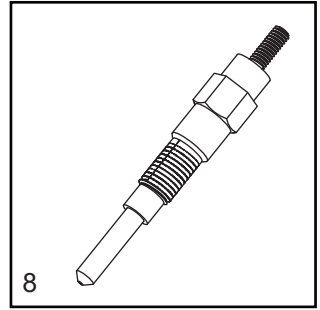
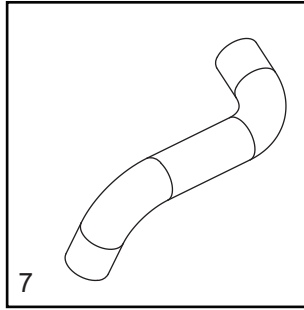
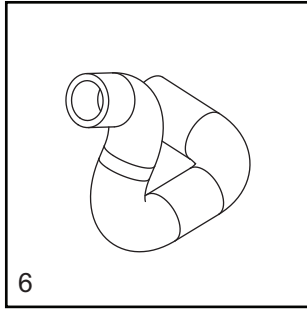
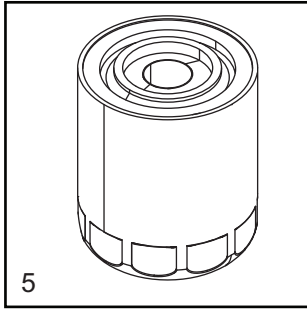
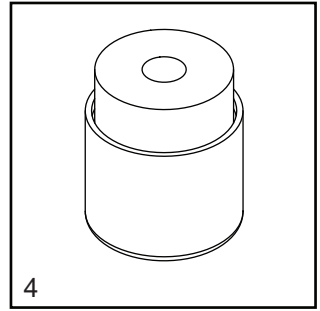
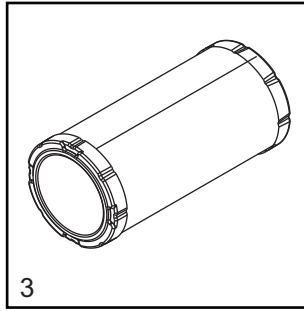
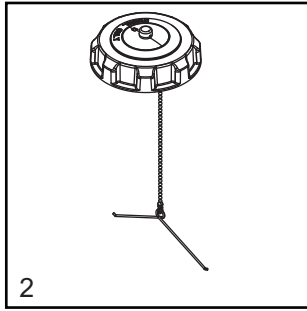
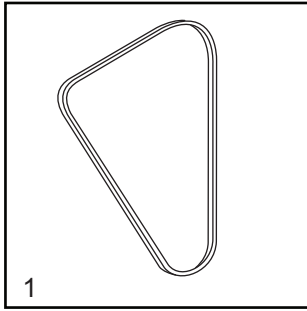



### ENGINE

1. Belt .....	39839
2. Cap, fuel tank with lanyard .....	16326
3. Filter, air (element).....	16444
4. Filter, fuel element .....	39840
5. Filter, oil .....	39842
6. Hose, lower radiator .....	31542
7. Hose, upper radiator.....	31543
8. Element, glow plug .....	16693
9. Pump, fuel .....	12994
10. Sender, coolant temp.....	12873
11. Starter .....	39843

# RECOMMENDED SPARE PARTS - ELECTRICAL

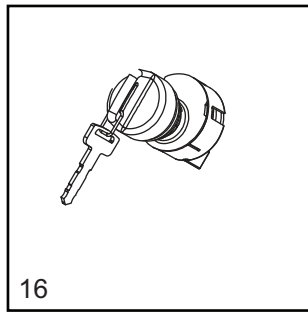
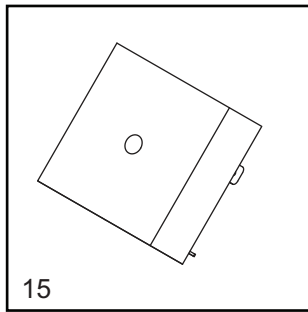
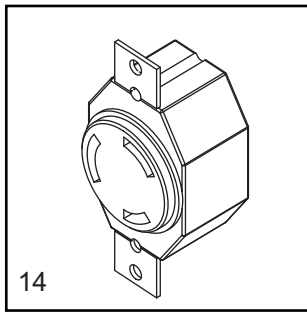
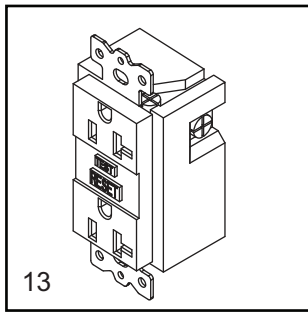
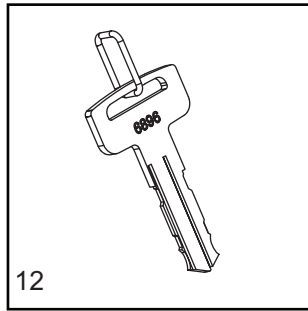
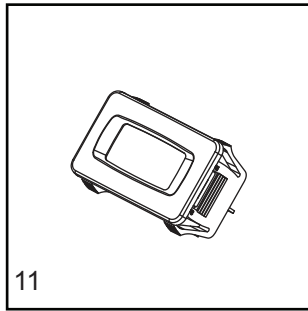
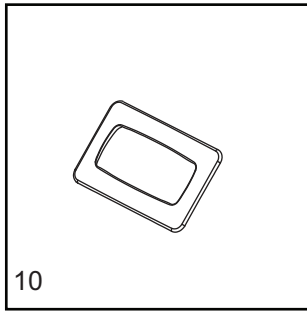
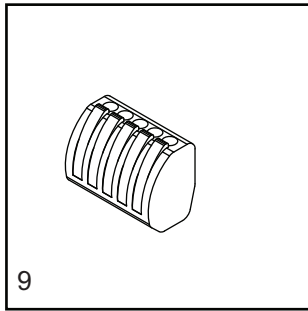
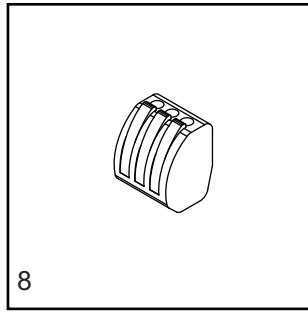
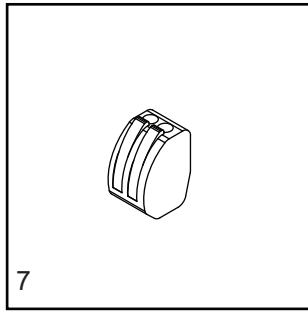
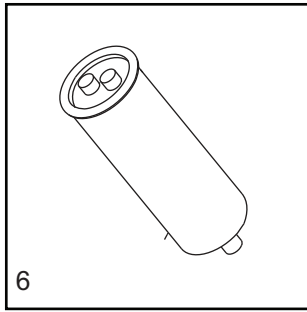
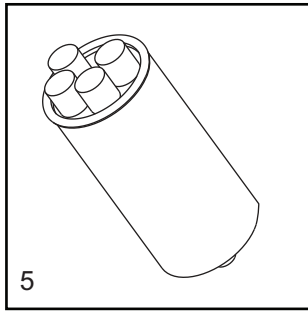
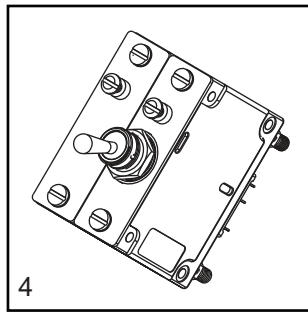
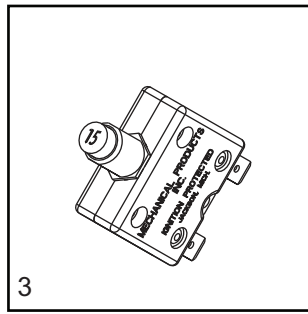
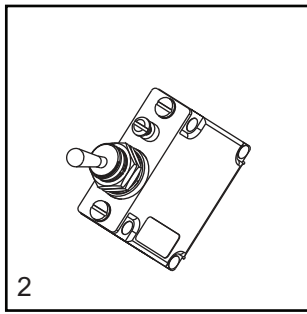
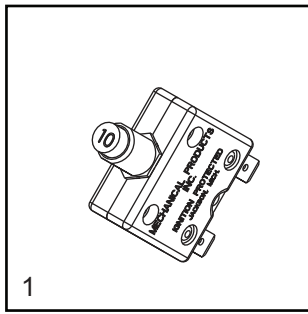

## RECOMMENDED SPARE PARTS - ELECTRICAL

---

### ELECTRICAL

1. Breaker, 10A, 240V, 1 pole, push button .....	36937
2. Switch, light - 15A .....	36880
3. Breaker, 15A, 120V, 1 pole, push button, 8kW .....	36935
4. Breaker, 30A, 250A, 2 pole, 6kW .....	36975
5. Capacitor, 24 $\mu$ F/24 $\mu$ F, 5% 540VAC dual .....	10000024477
6. Capacitor, 25 $\mu$ F, 440V, 6kW .....	36980
7. Connector, 2 position (qty - 4) .....	66100
8. Connector, 3 position (qty - 2) .....	66101
9. Connector, 5 position (qty - 1) .....	66102
10. Gasket, hour meter .....	36944
11. Gauge, hour meter.....	36886
12. Key (set of two).....	37182
13. Receptacle, 120V/20A GFI .....	14130
14. Receptacle, 240V/30A twist.....	14137
15. Relay, 10A SPDT, 15 second time delay .....	14201
16. Switch, key .....	36882

# RECOMMENDED SPARE PARTS - MISC

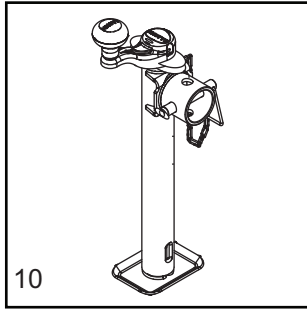
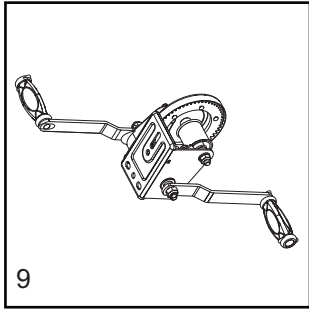
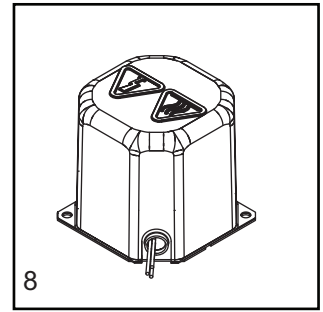
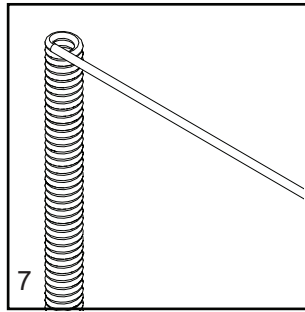
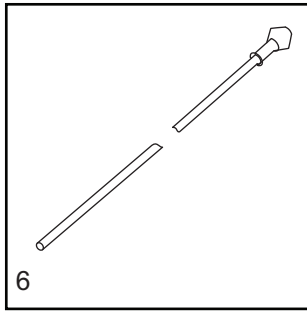
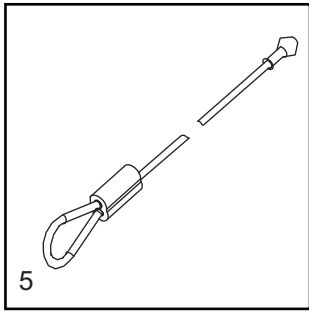
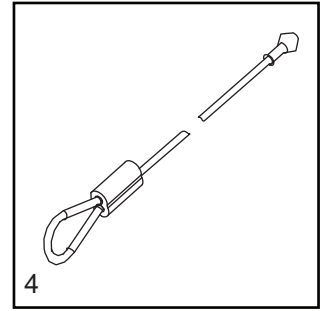
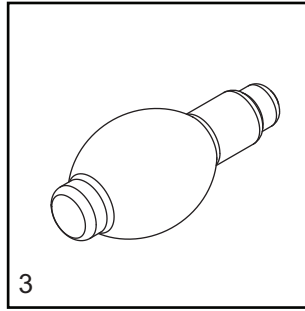
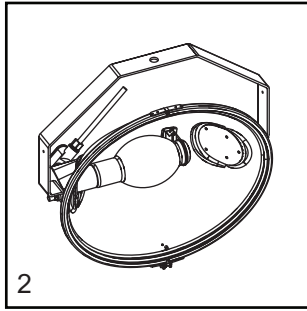
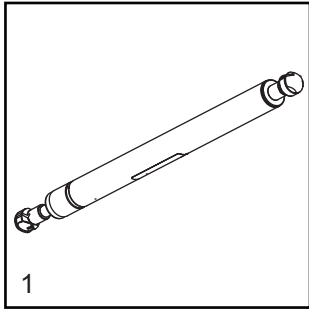

**ENCLOSURE**

- 1. Gas shock..... 35137

**MAST**

- 2. Assembly, light fixture, 1100W MH ..... 10000022353
- 3. Bulb, 1100W MH..... 10000022381
- 4. Cable, 79.75 in ..... 31248
- 5 Cable, 78 in ..... 31277
- 6. Cable, 144 in ..... 31247
- 7. Coil cord ..... 39650
- 8. Assembly, transformer can/base 60Hz MH 5.5 ..... 10000029380
- 9. Winch, manual, includes dual handle ..... 72127

**JACKS**

- 10. Jack, top wind, 1200 lb ..... 72126

This Page Intentionally Left Blank



Part No. 76182 Rev. C 04/13/2018

©2018 Generac Mobile Products, LLC  
All rights reserved.

Specifications are subject to change without notice.  
No reproduction allowed in any form without prior written consent  
from Generac Mobile Products, LLC.

**GENERAC**

**MOBILE  
PRODUCTS**

Generac Mobile Products, LLC  
215 Power Drive, Berlin, WI 54923

[GeneracMobileProducts.com](http://GeneracMobileProducts.com) | 800-926-9768 | 920-361-4442